

NOTES:

1. OPERATING TEMPERATURE -20°C TO 60°C
2. NEMA 4X, 316 STAINLESS STEEL, OR NEMA 4, POWDER COAT, CONSTRUCTION
3. FLAT KEYBOARD FOR WASHDOWN
4. OPTIONAL TABLE TOP, BULKHEAD, PEDESTAL OR CANTILEVER ARM MOUNT

DRAWN mcumbo	7/15/2009	<b>VARTECH SYSTEMS</b>			
CHECKED					TITLE
QA		<b>DIMENSIONAL DRAWING OF 15" TOUGHSTATION VT150ESWHB</b>			
MFG					
APPROVED		SIZE	TOLERANCES:	DWG NO	REV
		D	.XX = .015 .XXX = .005	482-0044-01	00
		SCALE			SHEET 1 OF 3

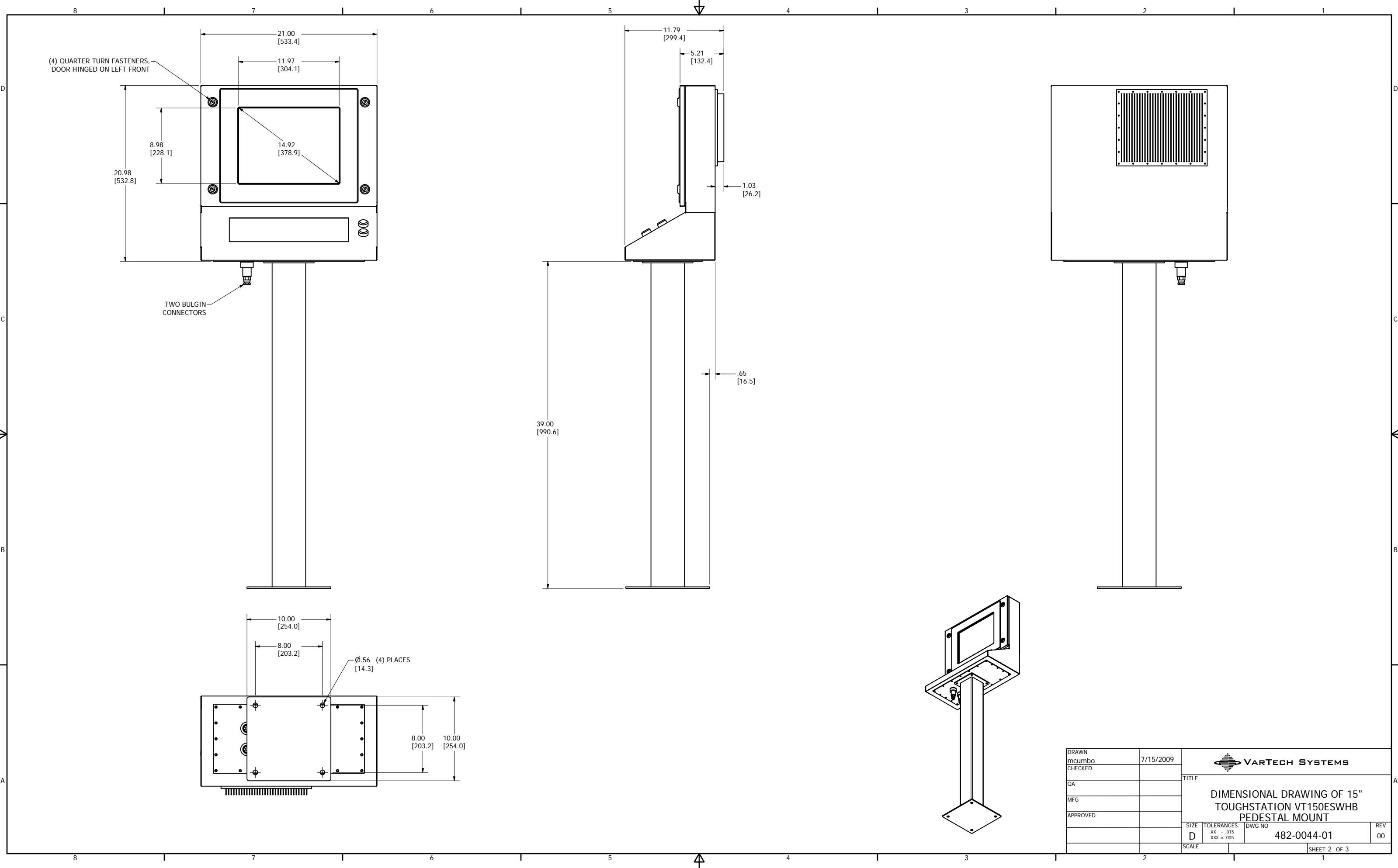

DRAWN	mcumbo	7/15/2009	<b>VARTECH SYSTEMS</b>			
CHECKED						
QA			TITLE			
MFG			<b>DIMENSIONAL DRAWING OF 15" TOUGHSTATION VT150ESWHB PEDESTAL MOUNT</b>			
APPROVED			SIZE	TOLERANCES:	DWG NO	REV
			D	.XX = .015 .XXX = .005	482-0044-01	00
			SCALE		SHEET 2 OF 3	

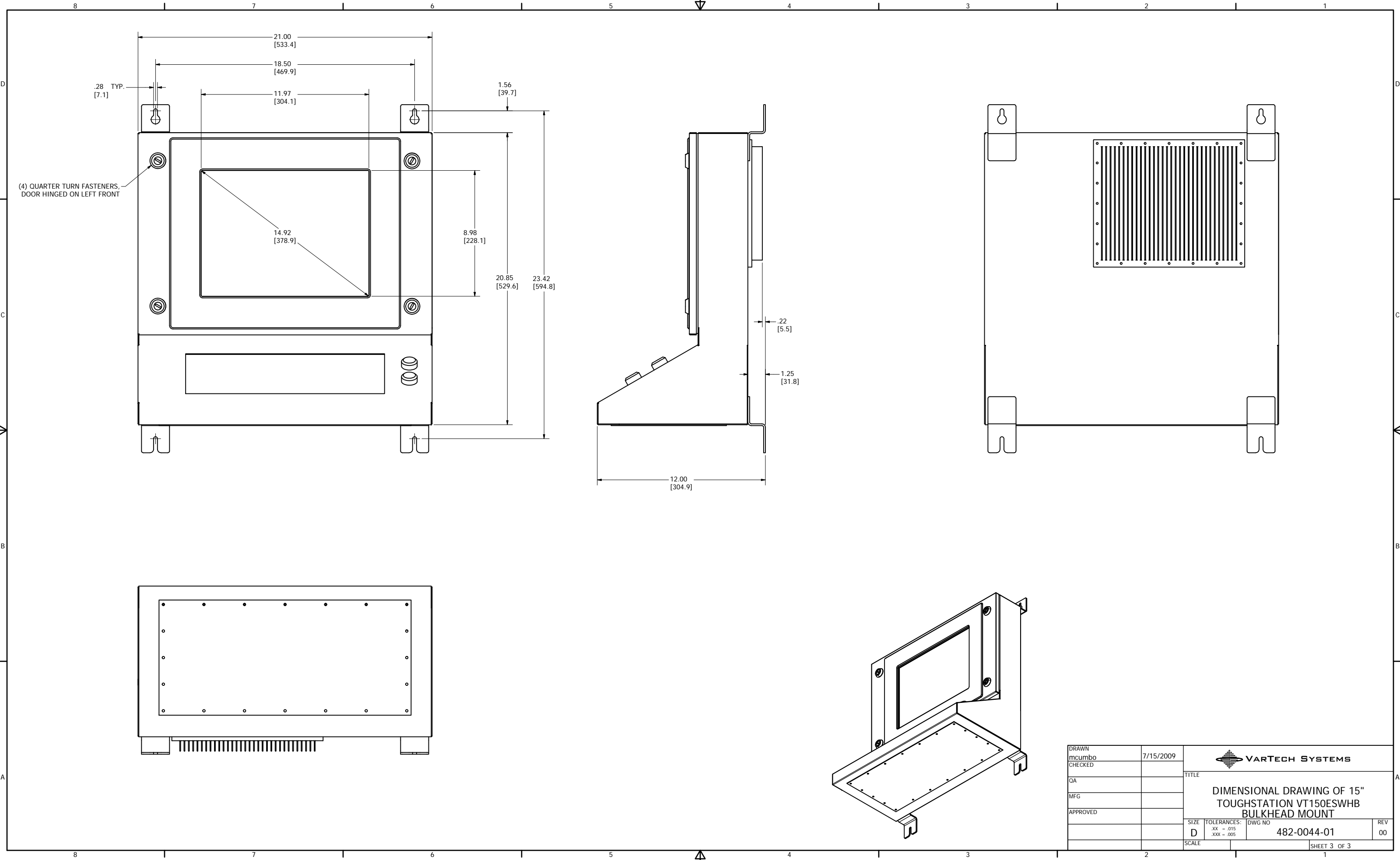

DRAWN	mcumbo	7/15/2009	<b>VARTECH SYSTEMS</b>			
CHECKED						
QA			TITLE			
MFG			<b>DIMENSIONAL DRAWING OF 15" TOUGHSTATION VT150ESWHB BULKHEAD MOUNT</b>			
APPROVED						
			SIZE	TOLERANCES:	DWG NO	REV
			D	.XX = .015 .XXX = .005	482-0044-01	00
			SCALE		SHEET 3 OF 3	

8 7 6 5 4 3 2 1

CHANGE HISTORY		
FILE INDEX	DESCRIPTION	APPROVAL INITIAL DATE
1		
2		

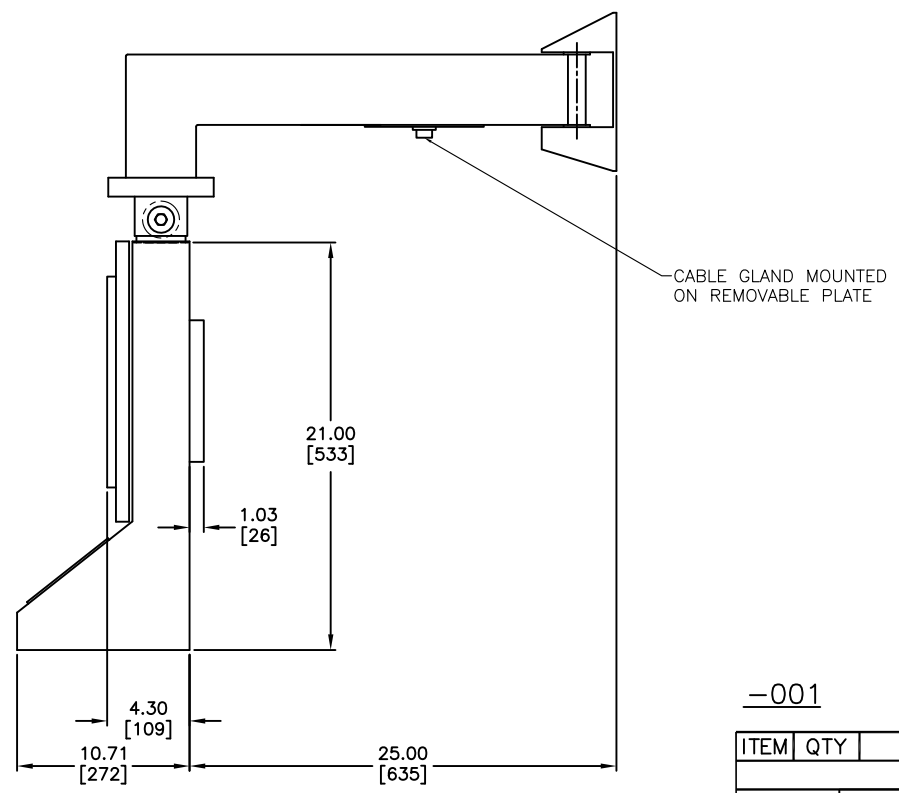
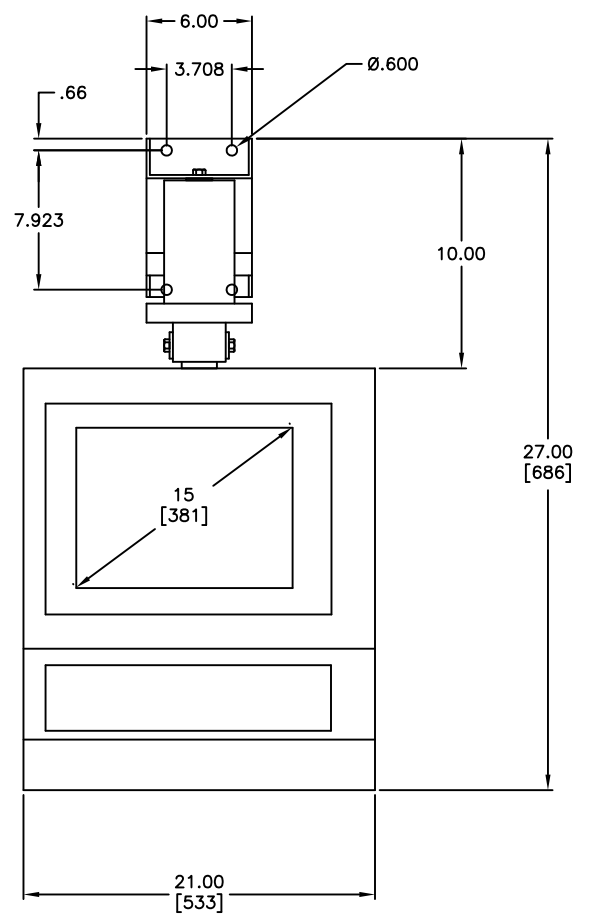
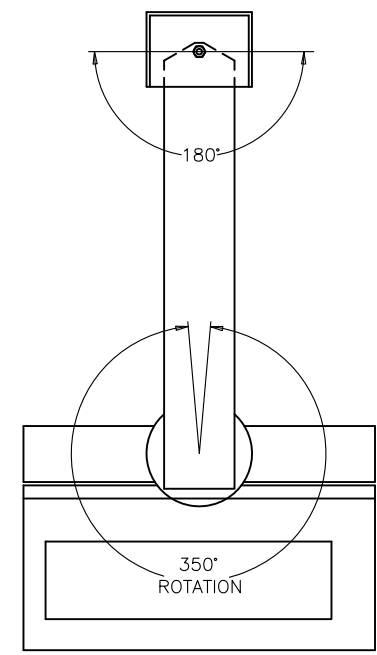

-001

ITEM	QTY	MFR. PT.NO.	DESCRIPTION	SYM/NOTE
LIST OF MATERIALS				
UNLESS OTHERWISE SPECIFIED DIMENSIONS ARE IN INCHES AND APPLY BEFORE FINISH SURFACE ROUGHNESS .125/ TOLERANCE ON FRACTIONS   DECIMALS   ANGLES ± 1/64   ±.XX=.02   ± 1/2		DRAWN NJM	DATE 6/10/09	<p><b>VARTECH SYSTEMS</b></p> <p>DIMENSIONAL DRAWING OF 15" TOUGHSTATION VT150ESWHB</p>
		CHECKED		
		DRAFTING		
		ENGINEER		
		MANUF		SIZE D
		APPROVED		DWG NO. 482-0042-04
		QA		REV 00
APPLICATION		SCALE 1 : 3		SHEET 1 OF 1

8 7 6 5 4 3 2 1

D

C

B

A

D

C

B

A