



Solutions for Demanding Applications

VarTech Systems Inc.

Industrial CRT and Flat Panel Displays



## VT181 ColorVue Series

18.1" Flat Panel Series LCD Monitors

VT181CC · VT181PC

VT181RC · VT181WC · VT181MC

User's Guide

**Read these instructions completely before attempting to operate your new Color Display.**

## Table Of Contents

Section	Page	Section	Page
<b>Section 1</b>		<b>Section 4</b>	
<b>Introduction</b>		<b>Touch screen</b>	
1.1 About LCD Monitors	1	4.1 Touch Screen Introduction	14
1.2 Product Safety Precautions	2	4.2 Touch Screen Installation	14
<b>Section 2</b>		<b>Section 5</b>	
<b>Display Setup</b>		<b>Troubleshooting Tips</b>	15-16
2.1 Display Features	3		
2.2 Unpacking The Display	4	<b>Section 6</b>	
2.3 Included Parts	4	<b>Cleaning &amp; Maintenance</b>	17
2.4 Connecting Your Display	4		
2.5 Signal Connections	4-6	<b>Section 7</b>	
		<b>Mechanical Drawings</b>	
<b>Section 3</b>		Panel Mount Instructions	18
<b>Getting Started</b>		Console Mount Mechanical Drawings	19
3.1 Adjusting the Display	7	Panel Mount Mechanical Drawings	20-21
3.2 Adjustment Procedure	8-9	Rack Mount Mechanical Drawings	22
3.3 OSD On Screen Display	10-13	Wall Mount Mechanical Drawings	23
		<b>Section 8</b>	
		<b>Display Specifications</b>	24

# 1

## 1.1 About LCD Monitors

*What you gain by using an LCD monitor in your industrial controls*

**LCDs** are the future of display technology. CRTs although they have dropped in cost significantly, do not offer the performance, reliability, and mounting options available with LCDs. LCD monitors consist primarily of an LCD, Video Board and a Back Light video. The LCD determines to a large extent the viewing angle, brightness and contrast. Beyond that it is the function of the video board which converts the analog RGB (Red, Green, Blue) signals from a standard video card to a high quality, digital RGB that the LCD can display.

Recently the video card has taken on a new role. It is the responsibility of this device to “scale” a particular video resolution to the “native” resolution of the LCD. Simply, consider that a computer is putting out a VGA [640x480] resolution signal, yet the LCD that is connected is an XGA [1024x768] display. The displayed picture would be in the center 1/3 of the LCD. With the introduction of the scaling engine. The converter will mathematically recalculate the 640x480 to 1024x768. This may sound simple but it is in fact a complex algorithm that adjusts for different aspect ratios and pixel alignment, essentially smoothing text and graphics to produce a picture that is pleasant to the eye.

All Vartech displays from 12.1” (800x600) to 23.1 (1600x1200) incorporate scaling engines in the converter card.

## 1.1 Product Safety Precautions

- ⇒ Ensure that sufficient space is available around the display to provide the circulation necessary for cooling.
- ⇒ Ensure that the ambient air temperature will not exceed the specified maximum temperature.
- ⇒ Do not attempt to service this display yourself. The rear chassis has a seal so that non qualified personal will not expose themselves to dangerous voltages or other risks.
- ⇒ To protect from electrical shock, unplug the display power supply from the wall before moving.
- ⇒ Do not expose the display to direct sunlight or heat.
- ⇒ Do not use this display near water
- ⇒ Do not place any heavy objects on the power cords. Damage may cause electrical shock.
- ⇒ Unplug the power supply from the wall or unit if one of the following conditions exists.
  - ⇒ Power cord or plug is damaged or frayed
  - ⇒ Liquid is spilled into the display or the display is exposed to rain or water.
  - ⇒ The display does not operate normally when the operating instructions are followed.
  - ⇒ The display has been dropped or the enclosure has been damaged.
  - ⇒ The display exhibits a distinct change in performance, indicating a need for service.

# 2

## **2.1 VT181 ColorVue Series Display Features**

- ⇒ Capable of displaying unlimited colors in a continuous spectrum. The high contrast LCD enhances the image with no geometric distortion.
- ⇒ The VT181 ColorVue Series directly accepts an analog 5 wire RGB with separate H/V sync or 4 wire RGB with separate combined sync or 3 wire SOG.
- ⇒ The VT181 ColorVue Series is auto synchronous adjusting the display to the appropriate input between VGA, SVGA,XGA, and SXGA.
- ⇒ The VT181 ColorVue Series is available in Panel Mount, Rack Mount, or Wall Mount industrial packages.
- ⇒ The VT181 ColorVue Series is supplied with a Anti-Reflective Screen unless equipped with an optional Touch System.
- ⇒ The VT181 ColorVue Series has an integrated 115/220VAC supply as standard on all models.

## 2.2 Unpacking and setting up your display

Your LCD monitor package will consist of the components listed below. Open shipping container and lay all components on a flat clean surface.

## 2.3 What is included with your display

- ⇒ VT181CC, VT181RC, VT181PC, VT181WC or VT181MC LCD Monitor
- ⇒ 5 ft Video Cable
- ⇒ 10-32 Mounting Hardware. (For use with Panel Mount only)
- ⇒ 6 ft RS232 Touch Interface Cable (Optional when touch is installed)
- ⇒ CD ROM with Touch Screen Drivers (Optional when touch is installed)
- ⇒ Users Guide (Printed or on CD)

## 2.4 Connecting the Display

1. Connect all cables to the computer first. This would include the VGA cable and the optional RS 232 serial touch screen connection.
2. After connecting the cables between the LCD monitor and the computer, plug the power cord into the 115/220VAC power outlet.
3. Once the 115/220VAC connection is made, the display is active.
4. If your computer was off, turn on your computer.
5. Your display should now operate as a normal computer display showing your windows or whatever video is being sent to the flat panel.

**Note:** If for any reason the display goes blank and gives an “out of Range” or “No Input Signal”, your computer or video source is putting out a signal that is out of range of the LCD’s video board. If this happens, reboot the computer or video source and make sure you are inputting the correct signal. If the display doesn’t work properly, it may be because:

- (a) The resolution is too high or low for the LCD.
- (b) The refresh rate is set too high. Refresh on an LCD is different than a CRT. Set the refresh to 60Hz. CRT’s need a high refresh rate to avoid flicker. The refresh rate has no impact on LCD’s.
- (c) The power source is incorrect.
- (d) The unit is malfunctioning. If you believe this to be true, disconnect the video cable from the rear of the LCD and connect to a known good computer CRT display. If the computer display is working satisfactory and the video is within the appropriate range, then contact Vartech Customer service for a RMA number at 800-223-8050.

## 2.5 Signal Connections

To avoid irregular operation and /or damage to the display, please insure correct video is being supplied as shown on the following page.

1. Connect all cables to the computer first. This would include the VGA cable and the optional RS 232 serial touch screen connection.
  2. After connecting the cables between the LCD monitor and the computer, plug the power cord into the 115/220VAC power outlet.
  3. Once the 115/220VAC connection is made, the display is active.
  4. If your computer was off, turn on your computer.
  5. Your display should now operate as a normal computer display showing your windows or whatever video is being sent to the flat panel.
- (a) The resolution is too high or low for the LCD.
- (b) The refresh rate is set too high. Refresh on an LCD is different than a CRT. Set the refresh to 60Hz. CRT's need a high refresh rate to avoid flicker. The refresh rate has no impact on LCD's.
- (c) The power source is incorrect.
- (d) The unit is malfunctioning. If you believe this to be true, disconnect the video cable from the rear of the LCD and connect to a known good computer CRT display. If the computer display is working satisfactorily and the video is within the appropriate range, then contact VarTech Customer service for a RMA number.

## 2.5 Signal Connections Cont.

You can use an HD-15 connector cable or a BNC adapter cable to connect the flat panel monitor to the host computer. The HD-15 video cable (supplied in the kit) you use with this monitor is equipped with a conventional HD-15 connector at each end.

**Note:** The following figure is the view looking into the pin end of the male connector or solder term end of the female connector.

### HD-15 Video Connector

The following table provides the pin numbers and corresponding pin assignments for the HD-15 video connector.

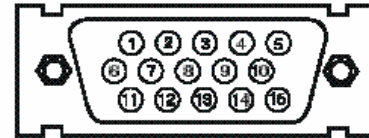

Pin	Signal (HD15)	Pin	Signal (HD15)	Pin	Signal (HD15)
1	Red Video	6	Red Video Ground	11	Not Used
2	Green Video	7	Green Video Ground	12	Bi-Directional Data
3	Blue Video	8	Blue Video Ground	13	Horizontal Sync
4	Not Used	9	No Connection	14	Vertical Sync
5	Return	10	Sync Ground	15	Data Clock (SCL)

### DVI-I Connector (Digital / Analog)

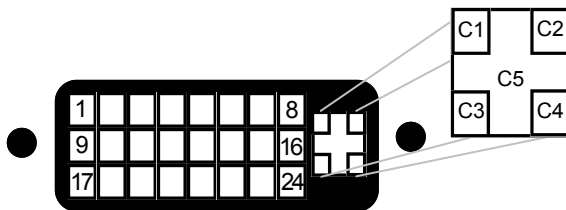

Pin	Signal (DVI-I)
C1	Analog Red
C2	Analog Green
C3	Analog Blue
C4	Analog H. Sync
C5	Analog Ground

Pin	Signal (DVI-I)	Pin	Signal (DVI-I)	Pin	Signal (DVI-I)
1	T.M.D.S. Data2-	9	T.M.D.S. Data1-	17	T.M.D.S. Data0-
2	T.M.D.S. Data2+	10	T.M.D.S. Data1+	18	T.M.D.S. Data0+
3	T.M.D.S. Data2/4 Shield	11	T.M.D.S. Data1/3 Shield	19	T.M.D.S. Data0/5 Shield
4	T.M.D.S. Data4-	12	T.M.D.S. Data3-	20	T.M.D.S. Data5-
5	T.M.D.S. Data4+	13	T.M.D.S. Data3+	21	T.M.D.S. Data5+
6	DDC Clock	14	+5V Power	22	T.M.D.S. Clock Shield
7	DDC Data	15	Ground (return for +5V, H. Sync and V. Sync)	23	T.M.D.S. Clock+
8	Analog Vertical Sync	16	Hot Plug Detect	24	T.M.D.S. Clock-

## 2.5 Signal Connections Cont.

### Optional BNC Adaptor Cable

A 5-BNC-to-HD-15 adapter cable is available. The functions of the cables are described below.

- ⇒ **R, B, and G:** Red, Green, and Blue input connectors to establish color. These are used for RS-343 analog signals.
- ⇒ **HS/CS:** Separate horizontal/composite sync signal from the video source.
- ⇒ **VS:** Separate vertical sync signal from the video source.

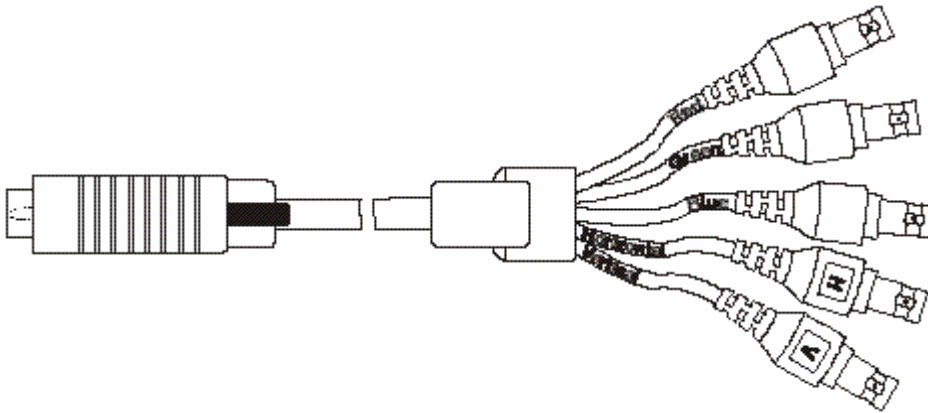

### BNC Adapter Cable

This table describes the signal types you can use with the connectors:

#### BNC Signal Types

BNC Signal Type	Description	R	G	B	HS / CS	VS
Sync-on-Green	Use the three video connectors. Horizontal and vertical syncs are supplied on the green video line.	X	X	X		
Composite Sync	Use the three video connectors plus the horizontal sync/composite sync input.	X	X	X	X	
Separate Horizontal and Vertical Sync.	Use the three video connectors plus the horizontal sync/composite sync and vertical sync input.	X	X	X	X	X

# 3

## Getting Started

### 3.1 Adjusting the display

The VT181 Series display has an embedded microprocessor in the converter card. Once you have the unit displaying the resolution you desire for your application do the following:

In order to navigate to the appropriate adjustments, press **Menu** and the OSD layout chart will appear as indicated in Fig. 1 from left to right.

If you press the “MENU” the new settings are saved and the OSM appear and your setting will be stored in the unit’s non volatile memory.

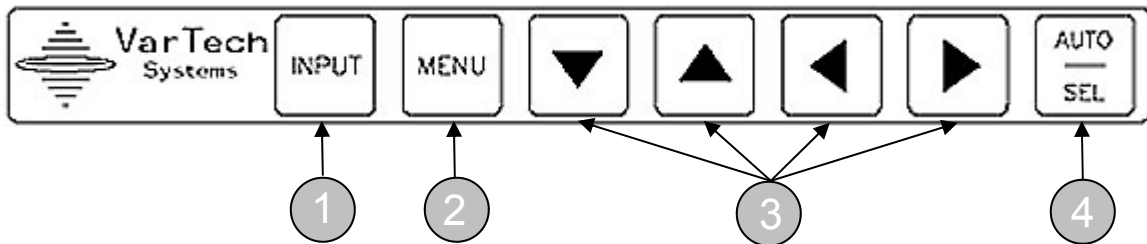

### 3.2 Control Panel Functions

Control	Function
<p>1 Input</p>	<p>Use this button to make Dsub or DVI connector active. This feature is used when two computers are connected to the display. The default setting is Dsub.</p>
<p>2 MENU</p>	<p>Use this button to enter or exit the On Screen Display.</p>
<p>3 ▼ ▲ ◀ ▶</p>	<p>Use these button to choose or adjust items in the On Screen Display.</p>
<p>4 AUTO / SEL</p>	<p>Use this button to enter a selection in the On Screen Display.</p>

## 3.2 Control Panel Functions Cont.

### Control

### Direct Access Function

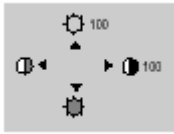

Bring up Contrast and Brightness adjustment.

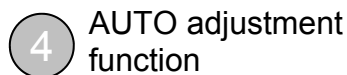

When adjusting your display settings, always press the AUTO/SELECT button before entering the On Screen Display (OSD). This will automatically adjust your display image to the ideal settings for the current screen resolution size (display mode). The best display mode is 1280 x 1024.



Controls Locked / Unlocked:  
MENU and

This function allows you to secure the current control settings, so that they cannot be inadvertently changed. Press and hold the MENU button and button for 3 seconds: the message "CONTROLS LOCKED" appears.



You can unlock the OSD controls at any time by pushing the MENU button and button for 3 seconds: the message "CONTROLS UNLOCKED" will appear.

### 3.3 On Screen Display (OSD) Control Adjustment

#### Screen Adjustment

Making adjustments to the image size, position and operating parameters of the display is quick and easy with the On Screen Display Control system. A short example is given below to familiarize you with the use of the controls. The following section is an outline of the available adjustments and selections you can make using the OSD.

#### NOTE

Allow the display to stabilize for at least 30 minutes before making image adjustments.

To make adjustments in the On Screen Display, follow these steps:

- 1) Press the MENU Button, then the main menu of the OSD appears.
- 2) To access a control, use the ▼ or ▲ Buttons.  
When the icon you want becomes highlighted, press the AUTO/ SELECT Button.
- 3) Use the ▼ ▲ ◀ ▶ Buttons to adjust the item to the desired level.
- 4) Accept the changes by pressing the AUTO/SELECT Button.
- 5) Exit the OSD by Pressing the MENU Button.

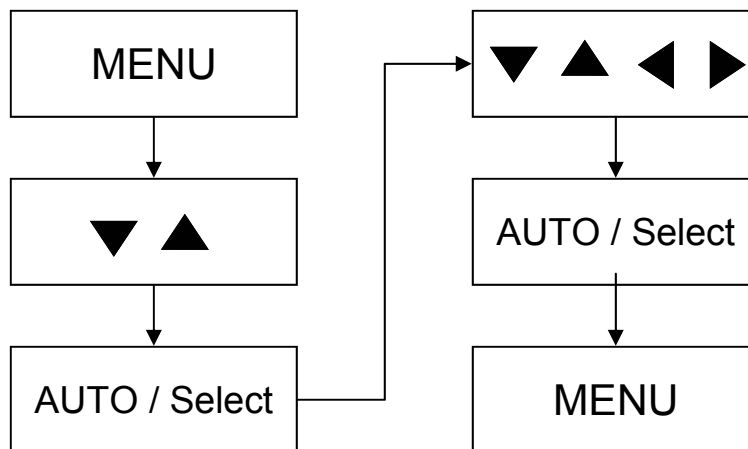

### 3.3 On Screen Display (OSD) Control Adjustment Cont.

The following table indicates all the On Screen Display control, adjustment, and setting menus.

Main Menu	Sub Menu		A	D	Reference
BRIGHTNESS	BRIGHTNESS		✓	✓	To adjust the brightness and contrast of the screen
CONTRAST	CONTRAST		✓	✓	
COLOR	PRESET	9300K	✓	✓	To customize the color of the screen
		6500K	✓	✓	
	R/G/B (User Color)		✓	✓	
POSITION	V POSITION		✓		To adjust the position of the screen
	H POSITION		✓		
TRACKING	CLOCK		✓		To improve the clarity and stability of the screen
	PHASE		✓		
SETUP	LANGUAGE		✓	✓	To customize the screen status for a user's operating environment
	IMAGE SIZE		✓	✓	
	OSD POSITION		✓	✓	
	SIGNAL		✓	✓	

Legend

✓: Adjustable

A: Analog Input

D: Digital Input

### 3.3 On Screen Display (OSD) Control Adjustment Cont.

You were introduced to the procedure of selecting and adjusting an item using the OSD system. Listed below are the icons, icon names, and icon descriptions of the all items shown on the Menu.

#### To adjust the brightness and contrast of the screen

OSD Agent

Description

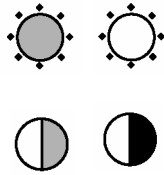
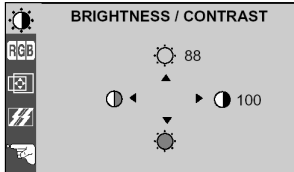

**BRIGHTNESS**

To adjust the brightness of the screen.

**CONTRAST**

To adjust the contrast of the screen.

#### To customize the color of the screen

OSD Agent

Description

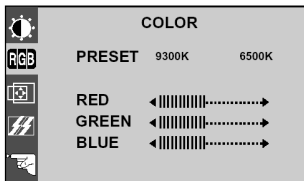

**PRESET**

**9300K / 6500K**

Select the screen color.

- 9300K: Slightly bluish white
- 6500K: Slightly reddish white

**RED**

**GREEN**

Set your own color levels.

**BLUE**

#### To adjust the brightness and contrast of the screen

OSD Agent

Description

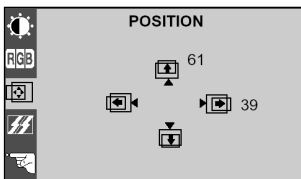

**VERTICAL POSITION**

To move the image up and down.



**HORIZONTAL POSITION**

To move the image left and right.

### 3.3 On Screen Display (OSD) Control Adjustment Cont.

To improve the clarity and stability of the screen

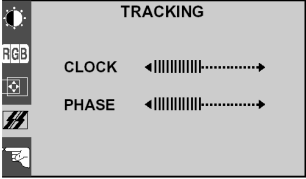
OSD Agent	Description
	<p><b>CLOCK</b> To minimize any vertical bars or stripes visible on the screen background. The horizontal screen size will also change.</p>
	<p><b>PHASE</b> To adjust the focus of the display This item allows you to remove any horizontal noise and clear or sharpen the image of characters.</p>

To customize the screen status for a user's operating environment

OSD Agent	Description
	<p><b>LANGUAGE</b> To choose the language in which the control names are displayed.</p>
	<p><b>IMAGE SIZE</b> This function displays the image in its original size so as to fit in the full screen of the LCD panel.</p>
	<p><b>OSD POSITION</b> To adjust position of the OSD window.</p>
	<p><b>SIGNAL</b> To select Dsub Analog, DVI Digital or DVI Analog / as the active input. This feature is used when two computers are connected to the display. The display automatically detects the proper input when only one video source is connected.</p>
	<p><b>ELAPSED TIME</b> To display the use time of display.</p>

# 4

## **4.1 Introduction**

Touch screens are a common means to interface operator inputs to a system. The universal standard of Windows GUI (Graphical User Interface) has significantly increased the use of touch screens.

There are four main touch technologies. The technologies are resistive, surface acoustic wave (SAW), capacitive, and infrared (IR). Each touch technology has advantages and disadvantages based on different user applications.

## **4.2 Installation**

All Vartech Systems displays configured with a touch screen are supplied with a CDROM which includes user manuals, application software, and drivers for various operating systems. Insert the supplied CDROM into a CDROM drive and follow the installation instructions that will appear on the screen.

Limited technical support is available by contacting Vartech Systems customer support at 800-223-8050.

# 5

## Troubleshooting

### No image appears

**Is the power cord of the display connected?**

Check and see if the power cord is connected properly to the power outlet

Press the Power button.

Adjust the brightness and the contrast.

If the display is in power saving mode, try moving the mouse or pressing any key on the keyboard to bring the screen up.

**Do you see an “INPUT SIGNAL OUT OF RANGE” message on the screen**

This message appears when the signal from the PC (video card) is out of horizontal or vertical frequency range of the display. See the Specifications' section of this manual and configure your display again.

**Do you see a “NO SIGNAL” message on the screen?**

This message appears when the signal cable between your PC and your display is not connected. Check the signal cable and try again.

### No image appears

**Have you installed the display driver?**

Be sure to install the display driver from the display CD that comes with your display.

## 5.0 Troubleshooting Cont.

### Display image is incorrect

**Display Position is incorrect.** Press the **AUTO / SELECT** button to automatically adjust your display image to the ideal setting.  
If the results are unsatisfactory, adjust the image position using the H position and V position icon in the on screen display.

**On the screen background, vertical bars or stripes are visible** Press the **AUTO / SELECT** button to automatically adjust your display image to the ideal setting.  
If the results are unsatisfactory, decrease the vertical bars or stripes using the **CLOCK** icon in the on screen display.

**Any horizontal noise appearing in any image or characters are not clearly portrayed.** Press the **AUTO / SELECT** button to automatically adjust your display image to the ideal setting.  
If the results are unsatisfactory, decrease the horizontal bars using the **PHASE** icon in the on screen display.

# 6

## Cleaning and Maintenance

### Cleaning

Occasionally clean the display panel and cabinet with a soft cloth dampened (not soaked) with a mild (non-abrasive) glass cleaner. Keep turning a fresh side of the cloth toward the screen surface to avoid scratching it with accumulated grit.

**Note:** The solvent (a 50/50 mixture isopropyl alcohol and water) should be applied only to the cloth, and not directly on the monitor screen.

Do not use paper products as they may scratch the surface. To minimize the risk of abrasion, allow the screen to stand dry.

Special care should be taken when cleaning a touch screen or polycarbonate shield that is installed over the screen. Abrasive and certain chemical cleaners can easily damage the surface.

**Never** use alcoholic or ammoniac cleaners to clean the polycarbonate shield or a touch screen.

### Replacing a Line Cord

To avoid shock and fire hazards, the monitor's power cord should be replaced if the insulation becomes broken or if it develops a loose internal connection.

### Other Maintenance

Qualified service personnel should perform all maintenance, except for the power cord replacement described above.

## Mechanical Drawings

Model	Description	Page(s)
VT181CC	18.1" DiamondVue Chassis Mount Mechanical Drawing	19
VT181PC	18.1" DiamondVue Panel Mount Mechanical Drawing	20-21
VT181RC	18.1" DiamondVue Rack Mount Mechanical Drawing	22
VT181WC	18.1" DiamondVue Wall/Arm Mechanical Drawing	23

### 7.1 Panel Mount Procedure

#### Panel Mounting Procedure

1. Cut and drill the panel (refer to panel mount drawing). Measurements are in inches.

#### Panel Mounting Cutout

2. If access to the side of the monitor is not available following installation, attach the power and video cables to the side of the monitor at this time.
3. Install the monitor in the prepared cutout.
4. Install the lock nuts and washers, supplied with the monitor, behind the holes running along the sides and top/bottom of the cutout in the panel. Extra lock nuts and washers are provided.

**Note:** Use #10-32 nuts for mounting.

5. Tighten all mounting nuts evenly to a torque of 24 inch-pounds.

**ATTENTION:** Mounting nuts must be tightened to a torque of 24 inch-pounds to provide panel seal and avoid potential damage. Vartech Systems assumes no responsibility for water or chemical damage to the monitor or other equipment within the enclosure due to improper installation.

6. Attach the power and video cables to the side of the monitor if you have not already done so.

Generic Panel Mount Diagram

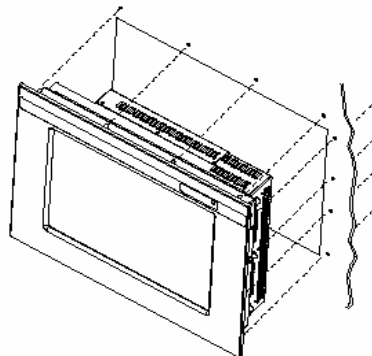

# 8

## Specifications

Panel Size	18.1"
Type	TFT Active matrix w/ Anti-Glare coating
Pixel Pitch	0.28mm
Max. Resolution	1280 x 1024 @ 75Hz (Analog) 1280 x 1024 @ 60Hz (Digital)
Active Diagonal	18.1" Viewable
Active Screen Area	14.135" x 11.308" 359.03mm x 287.22mm
Pixel Format	640 x 480, 800 x 600, 1024 x 768, 1280 x 1024
Viewing Angle (Up/Down)	80/80 deg.
Viewing Angle (Left/Right)	80/80 deg.
Contrast Ratio	350:1
Brightness	250 Nits
Response Time	$T_R = 20\text{ms}$ $T_D = 30\text{ms}$
Back Lights	Cold Cathode 50,000 Hrs. Half Life
Video Connectors	HD15(F) DVI-I 29Pin connector (Digital/Analog)
Video Input	RGB Analog (0.7 p-p / 75ohm) , Digital
Sync	Separate H&V, Combined, SOG (Sync On Green), Digital
Colors Supported	16.8M
Horizontal Frequency	30-80kHz (automatic)
Vertical Frequency	56-85Hz (automatic)
Power Input	AC 100-240V 50/60Hz 1.0A
Power consumption	Normal: 55 Watts Stand-by/Suspend: 3 Watts Power Off: 3 Watts
Operating Temperature	0 to 50°C
Storage Temperature	-20 to 60°C
Operating Humidity	10 to 95% NC
Storage Humidity	5 to 95% NC
Operating Altitude	Up to 10,000 ft
Storage Altitude	Up to 50,000 ft

**VARTECH SYSTEMS INC.**

**HEADQUARTERS**

11529 Sun Belt Ct.

Baton Rouge, Louisiana 70809

Toll-Free: 800.223.8050

International Phone: 001.225.298.0300

Fax: 225.297.2440

E-mail: [sales@vartechsystems.com](mailto:sales@vartechsystems.com)

**[www.vartechsystems.com](http://www.vartechsystems.com)**