



Solutions for Demanding Applications

VarTech Systems Inc.

Industrial CRT and Flat Panel Displays



VT181 DiamondVue Series 18.1" Flat Panel Series LCD Monitors

VT181P · VT181W · VT181R · VT181CB

VT181P-SS · VT181PI · VT181R-SS

Transflectives:

VT181PTSR · VT181PTSRSS

VT181RTSR · VT181WTSR

User's Guide

Read these instructions completely before attempting to operate your new Color Display.

Table Of Contents

Section	Page	Section	Page
Section 1		Section 4	
Introduction		Touch screen	
1.1 About LCD Monitors	1	Touch Screen Introduction	10
1.2 Product Safety Precautions	2		
		Section 5	
Section 2		Troubleshooting Tips	11-12
Display Setup			
2.1 Display Features	3	Section 6	
2.2 Unpacking The Display	4	Cleaning & Maintenance	13
2.3 Included Parts	4		
2.4 Connecting Your Display	4	Section 7	
2.5 Signal Connections	4-6	Mechanical Drawings	
		Panel Mount Instructions	14
Section 3		Panel Mount Mechanical Drawings	15-18
Getting Started		Rack Mount Mechanical Drawings	19-20
3.1 Adjusting the Display	7	Wall Mount Mechanical Drawings	21
3.2 Adjustment Procedure	8-9	Intecolor Configured Mechanical Drawings	22-23
		Section 8	
		Display Specifications	24

1

1.1 About LCD Monitors

What you gain by using an LCD monitor in your industrial controls

LCDs are the future of display technology. Although CRTS have dropped in cost significantly, they do not offer the performance, reliability, and mounting options available with LCDs. LCD monitors consist primarily of an LCD, Video Board and a Back Light video. The LCD determines to a large extent the viewing angle, brightness and contrast. Beyond that it is the function of the video board which converts the analog RGB (Red, Green, Blue) signals from a standard video card to a high quality, digital RGB that the LCD can display.

Recently the video card has taken on a new role. It is the responsibility of this device to “scale” a particular video resolution to the “native” resolution of the LCD. Simply, consider that a computer is putting out a VGA [640x480] resolution signal, yet the LCD that is connected is an XGA [1024x768] display. The displayed picture would be in the center 1/3 of the LCD. With the introduction of the scaling engine. The converter will mathematically recalculate the 640x480 to 1024x768. This may sound simple but it is in fact a complex algorithm that adjusts for different aspect ratios and pixel alignment, essentially smoothing text and graphics to produce a picture that is pleasant to the eye.

All Vartech displays from 12.1” (800x600) to 23.1 (1600x1200) incorporate scaling engines in the converter card.

1.1 Product Safety Precautions

- ⇒ Ensure that sufficient space is available around the display to provide the circulation necessary for cooling.
- ⇒ Ensure that the ambient air temperature will not exceed the specified maximum temperature.
- ⇒ Do not attempt to service this display yourself. The rear chassis has a seal so that non qualified personal will not expose themselves to dangerous voltages or other risks.
- ⇒ To protect from electrical shock, unplug the display power supply from the wall before moving.
- ⇒ Do not expose the display to direct sunlight or heat.
- ⇒ Do not use this display near water
- ⇒ Do not place any heavy objects on the power cords. Damage may cause electrical shock.
- ⇒ Unplug the power supply from the wall or unit if one of the following conditions exists.
 - ⇒ Power cord or plug is damaged or frayed
 - ⇒ Liquid is spilled into the display or the display is exposed to rain or water.
 - ⇒ The display does not operate normally when the operating instructions are followed.
 - ⇒ The display has been dropped or the enclosure has been damaged.
 - ⇒ The display exhibits a distinct change in performance, indicating a need for service.

2

2.1 VT181 Series Display Features

- ⇒ Capable of displaying unlimited colors in a continuous spectrum. The high contrast LCD enhances the image with no geometric distortion.
- ⇒ The VT181 DiamondVue Series directly accepts an analog 5 wire RGB with separate H/V sync or 4 wire RGB with separate combined sync or 3 wire SOG.
- ⇒ The VT181 DiamondVue Series is auto synchronous adjusting the display to the appropriate input between VGA, SVGA, XGA, and SXGA.
- ⇒ The VT181 DiamondVue Series is available in Panel Mount, Rack Mount, or Wall Mount industrial packages.
- ⇒ The VT181 DiamondVue Series is supplied with a Anti-Reflective Screen unless equipped with an optional Touch System.
- ⇒ The VT181 DiamondVue Series has an integrated 115/220VAC supply as standard on all models.

2.2 Unpacking and setting up your display

Your LCD monitor package will consist of the components listed below. Open shipping container and lay all components on a flat clean surface.

2.3 What is included with your display

- ⇒ VT181R or VT181P, or VT181W LCD Monitor
- ⇒ 5 ft Video Cable
- ⇒ 10-32 Mounting Hardware. (For use with Panel Mount only)
- ⇒ 6 ft RS232 Touch Interface Cable (Optional when touch is installed)
- ⇒ CD ROM with Touch Screen Drivers (Optional when touch is installed)
- ⇒ Users Guide (Printed or on CD)

2.4 Connecting the Display

1. Connect all cables to the computer first. This would include the VGA cable and the optional RS 232 serial touch screen connection.
2. After connecting the cables between the LCD monitor and the computer, plug the power cord into the 115/220VAC power outlet.
3. Once the 115/220VAC connection is made, the display is active.
4. If your computer was off, turn on your computer.
5. Your display should now operate as a normal computer display showing your windows or whatever video is being sent to the flat panel.

Note: If for any reason the display goes blank and gives an “out of Range” or “No Input Signal”, your computer or video source is putting out a signal that is out of range of the LCD’s video board. If this happens, reboot the computer or video source and make sure you are inputting the correct signal. If the display doesn’t work properly, it may be because:

- (a) The resolution is too high or low for the LCD.
- (b) The refresh rate is set too high. Refresh on an LCD is different than a CRT. Set the refresh to 60Hz. CRT’s need a high refresh rate to avoid flicker. The refresh rate has no impact on LCD’s.
- (c) The power source is incorrect.
- (d) The unit is malfunctioning. If you believe this to be true, disconnect the video cable from the rear of the LCD and connect to a known good computer CRT display. If the computer display is working satisfactory and the video is within the appropriate range, then contact Vartech Customer service for a RMA number at 800-223-8050.

2.5 Signal Connections

To avoid irregular operation and /or damage to the display, please insure correct video is being supplied as shown on the following page.

2.5 Signal Connections Cont.

You can use an HD-15 connector cable or a BNC adapter cable to connect the flat panel monitor to the host computer. The HD-15 video cable (supplied in the kit) you use with this monitor is equipped with a conventional HD-15 connector at each end.

Note: The following figure is the view looking into the pin end of the male connector or solder term end of the female connector.

HD15 Connector					
The following table provides the pin numbers and corresponding pin assignments for the HD-15 video connector.					
Pin	Signal	Pin	Signal	Pin	Signal
1	Red Video	6	Red Video Ground	11	Not Used
2	Green Video	7	Green Video Ground	12	Bi-Directional Data
3	Blue Video	8	Blue Video Ground	13	Horizontal Sync
4	Not Used	9	No Connection	14	Vertical Sync
5	Return	10	Sync Ground	15	Data Clock (SCL)

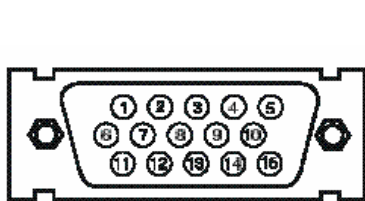

HD15 Connector

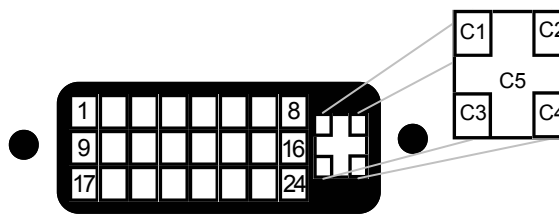

DVI-I Connector
(Digital / Analog)

DVI-I	
Pin	Signal
C1	Analog Red
C2	Analog Green
C3	Analog Blue
C4	Analog H. Sync
C5	Analog Ground

DVI-I					
Pin	Signal	Pin	Signal	Pin	Signal
1	T.M.D.S. Data2-	9	T.M.D.S. Data1-	17	T.M.D.S. Data0-
2	T.M.D.S. Data2+	10	T.M.D.S. Data1+	18	T.M.D.S. Data0+
3	T.M.D.S. Data2/4 Shield	11	T.M.D.S. Data1/3 Shield	19	T.M.D.S. Data0/5 Shield
4	T.M.D.S. Data4-	12	T.M.D.S. Data3-	20	T.M.D.S. Data5-
5	T.M.D.S. Data4+	13	T.M.D.S. Data3+	21	T.M.D.S. Data5+
6	DDC Clock	14	+5V Power	22	T.M.D.S. Clock Shield
7	DDC Data	15	Ground (return for +5V, H. Sync and V. Sync)	23	T.M.D.S. Clock+
8	Analog Vertical Sync	16	Hot Plug Detect	24	T.M.D.S. Clock-

Composite Video Input Connector: CVBS 1.0V p-p

S-Video: S-VHS

LUMA Signal Input 0.7V p-p

CHROMA Signal Input 0.7V p-p

2.5 Signal Connections Cont.

Optional BNC Adaptor Cable

A 5BNC-to-HD15 adapter cable is available. The functions of the cables are described below.

- ⇒ **R, B, and G:** Red, Green, and Blue input connectors to establish color. These are used for RS-343 analog signals.
- ⇒ **HS/CS:** Separate horizontal/composite sync signal from the video source.
- ⇒ **VS:** Separate vertical sync signal from the video source.

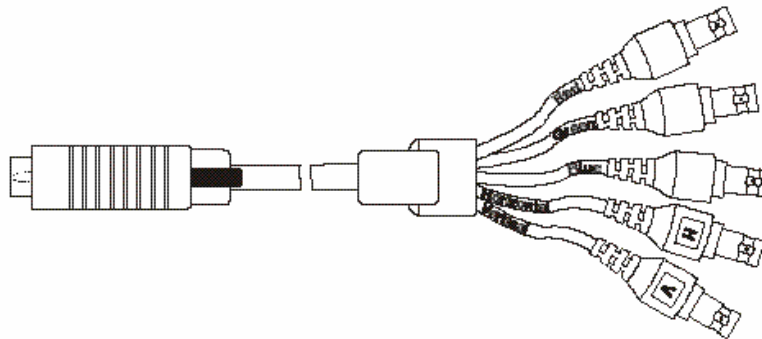

BNC Adapter Cable

This table describes the signal types you can use with the connectors:

BNC Signal Types						
BNC Signal Type	Description	R	G	B	HS/ CS	VS
Sync-on-Green (Not Available)	Use the three video connectors. Horizontal and vertical syncs are supplied on the green video line.	X	X	X		
Composite Sync (Not available)	Use the three video connectors plus the horizontal sync/ composite sync input	X	X	X	X	
Separate Horizontal and Vertical Sync.	Use the three video connectors plus the horizontal sync/ composite sync and vertical sync input.	X	X	X	X	X

3.1 Adjusting the display

The VT181 DiamondVue Series display has an embedded microprocessor in the converter card. Once you have the unit displaying the resolution you desire for your application do the following:

In order to navigate to the appropriate adjustments, press **Menu** and the OSD layout chart will appear as indicated as shown below.



3.2 Definition of OSD (on screen display) Adjustments

There are seven membrane buttons (as shown above) located on the unit. They will activate the OSD and allow navigation to all adjustments if your unit requires adjustment.

Press MENU and a major adjustment category will appear. Press DOWN or UP and you will see the remaining adjustment categories. The actual adjustment categories are listed under each major category (**bold**) as shown below.

On Screen Display	
Major Category	Adjustment Category
ADJUSTMENT	Brightness Contrast Clock Phase H Position V Position Auto
COLOR ADJUSTMENT	User 6500 9300
SETUP	Language Image Size OSD H Position OSD V Position Transparency Zoom

3.3 Adjustment

To adjust the brightness and contrast of the screen

OSD Agent

Description



Brightness	Adjusts the brightness of video without affecting PC RGB's brightness
Contrast	Adjusts the contrast of video without affecting PC RGB's contrast
Clock	Removes the noises. When frequency value is wrong, the image has horizontal lines especially in 1 dot on and off.
Phase	Removes the noises. When phase value is wrong, the image has vertical lines especially in 1 dot on and off.
H Position	Adjusts the horizontal position of the image.
V Position	Adjusts the vertical position of the image.
Auto Adjust	"Auto adjustment" allows the monitor to self-adjust to the incoming video signal. The values of phase, frequency and position are adjusted automatically.

This function is active if you select an input source other than PC. (DVD, VCR, TV)

OSD Agent

Description



Brightness	Adjusts the brightness of video or TV without affecting PC RGB's brightness.
Contrast	Adjusts the contrast of video or TV without affecting PC RGB's contrast.
Color	Changes the richness of color.
Tint	Changes the tone of color.
Sharpness	Adjusts the sharpness of video or TV image.

This function is active if you select a digital DVI input source.

OSD Agent

Description



Brightness	Adjusts the brightness of video or TV without affecting PC RGB's Brightness.
-------------------	--

3.3 Adjustment Cont.

Selects the applied input among DVI digital, Analog RGB, Video and S-VHS

OSD Agent	Description
	DVI Digital Selects the DVI Digital function.
	Analog RGB Selects the Analog RGB function.
	Video Selects the Video function.
	S-VHS Selects the S-VHS function.

To adjust the tone of color from redish white to bluish white.
The individual color components are also user customizable.

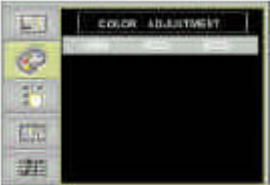
OSD Agent	Description
	6500° K Redish white
	9300° K Bluish White
	User User Customizable

To adjust OSD menu information

OSD Agent	Description
	Language English, German, French, Italian, Spanish
	Image Size Changes the image size in several different ways
	OSD H pos Moves the OSD Window to the horizontal direction.
	OSD V pos Moves the OSD Window to the vertical direction.
	Transparency Changes the opaqueness of the background of the OSD
	Zoom Closes up or down the main display
	Information Displays current display mode. Displays the driver board operating duration.

4

4.1 Introduction

Touch screens are a common means to interface operator inputs to a system. The universal standard of Windows GUI (Graphical User Interface) has significantly increased the use of touch screens.

There are four main touch technologies. The technologies are resistive, surface acoustic wave (SAW), capacitive, and infrared (IR). Each touch technology has advantages and disadvantages based on different user applications.

4.2 Installation

All Vartech Systems displays configured with a touch screen are supplied with a CDROM which includes user manuals, application software, and drivers for various operating systems. Insert the supplied CDROM into a CDROM drive and follow the installation instructions that will appear on the screen.

Limited technical support is available by contacting Vartech Systems customer support at 800-223-8050.

Troubleshooting	
Trouble	Troubleshooting Tip
No Picture	<ul style="list-style-type: none"> ⇒ The signal cable should be properly connected to the display card and computer. ⇒ Try disconnecting the video cable from the display and connecting to a CRT display if available to confirm the presence of proper video. ⇒ Make sure power is connected to the proper DC or AC source. ⇒ Make sure the resolution mode is supported by the display and check settings of the display card. ⇒ Confirm that the video cable is not defective.
Image Persistence	Image persistence occurs when a ghost of an image remains on the screen after the monitor has been turned off. Unlike a CRT monitor, an LCD monitor's image persistence is not permanent. To erase an image ghost, turn the monitor off for as long as the image was displayed. If the image was on for one hour and the ghost of the image remains, the display should be turned off for one hour to erase the image. To avoid this problem, use a screen saver.
Picture Quality & Image Stability	<ul style="list-style-type: none"> ⇒ Check for proper video cable for proper grounding and shielding. ⇒ Check the signal source for proper signal. ⇒ Check for proper adjustment of the Phase and Frequency controls. ⇒ Check for proper recommended signal timing.
Green LED not lit	Check for proper power and power connections
Green LED blinking	This indicates absence of video or proper video for this display
Display image is not properly sized	<ul style="list-style-type: none"> ⇒ Adjust the Vertical and Horizontal size controls via the OSD. (Reference setup adjustments) ⇒ Ensure that a supported mode is selected on the display card or system being used. Consult the display card or system manual for proper video.
No S-Video or NTSC operation	<ul style="list-style-type: none"> ⇒ Check for proper connections. ⇒ Check the setup instructions for proper input selection.
If these tips do not solve your problem, contact Vartech Systems Customer Service support.	

Troubleshooting Cont.

Trouble	Troubleshooting Tip
Screen is blank.	Screen saver activated. Video Cable problem. Check for proper installation Change video cable . Faulty video display. Needs Service.
Image is dim, even with brightness and contrast controls set full UP	Video cable problem. Check for proper installation of cables Faulty video source. Faulty display.
Image not centered	Reset the horizontal and vertical positioning using the on-screen menu. Check to see if video source is operating within the monitor's range
Image will not adjust	Video timing outside of range. Use the on-screen menu to adjust the Clock Setting. Make sure timing is within VESA standard.
Image is not stable.	Monitor has incorrect or bad sync signals. Check for proper video cable installation. Replace suspected faulty cable. Check to ensure that video source is operating within the display's range.
Vertical shaded bars on Screen image	Horizontal size not properly adjusted. Adjust horizontal size settings
Colors are missing	Faulty video cable. Missing from video source. Connect video source to another display
Screen jitter or noisy display	Monitor clock phase not properly adjusted
Slight distortion in text or Graphics.	Not working in native resolution.
Display is present but "bars" Appear or roll across screen	Ground loop problem between computer and display Interference from adjacent equipment
The background looks Acceptable but text and Icons seem to be missing rows of pixels	Video running interlace mode.

6

CLEANING AND MAINTANENCE

Cleaning

Occasionally clean the display panel and cabinet with a soft cloth dampened (not soaked) with a mild (non-abrasive) glass cleaner. Keep turning a fresh side of the cloth toward the screen surface to avoid scratching it with accumulated grit.

Note:

The solvent should be applied only to the cloth, and not directly on the monitor screen.

Do not use paper products as they may scratch the surface. To minimize the risk of abrasion, allow the screen to stand dry.

Special care should be taken when cleaning a touch screen or polycarbonate shield that is installed over the screen. Abrasive and certain chemical cleaners can easily damage the surface.

Never use alcoholic or ammoniac cleaners to clean the polycarbonate shield or a touch screen.

Note:

For best results cleaning a monitor with the optional antireflective tempered glass display shield, a solution of denatured alcohol is recommended to thoroughly clean the display.

Replacing a Line Cord

To avoid shock and fire hazards, the monitor's power cord should be replaced if the insulation becomes broken or if it develops a loose internal connection.

Other Maintenance

Qualified service personnel should perform all maintenance, except for the power cord replacement described above.

Mechanical Drawings

Model	Description	Page(s)
VT181P	18.1" DiamondVue Panel Mount Mechanical Drawing	15-18
VT181R	18.1" DiamondVue Rack Mount Mechanical Drawing	19-20
VT181W	18.1" Wall Mount Mechanical Drawing	21
VT181PI	18.1" Intecolor Configured Mechanical Drawing	22-23

7.1 Panel Mount Procedure

Panel Mounting Procedure

1. Cut and drill the panel (refer to panel mount drawing). Measurements are in inches.

Panel Mounting Cutout

2. If access to the side of the monitor is not available following installation, attach the power and video cables to the side of the monitor at this time.
3. Install the monitor in the prepared cutout.
4. Install the lock nuts and washers, supplied with the monitor, behind the holes running along the sides and top/bottom of the cutout in the panel. Extra lock nuts and washers are provided.

Note:

Use #10-32 nuts for mounting.

5. Tighten all mounting nuts evenly to a torque of 24 inch-pounds.

ATTENTION: Mounting nuts must be tightened to a torque of 24 inch-pounds to provide panel seal and avoid potential damage. Vartech Systems assumes no responsibility for water or chemical damage to the monitor or other equipment within the enclosure due to improper installation.

6. Attach the power and video cables to the side of the monitor if you have not already done so.

Generic Panel Mount Diagram

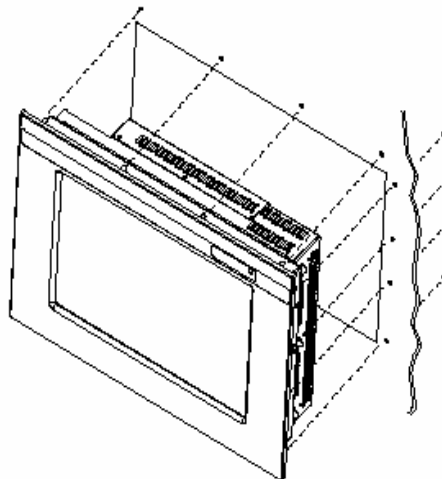

8

SPECIFICATIONS

ENGINEERING SPECIFICATIONS	
Panel Size	18.1"
Type	TFT Active matrix w/ Anti-Glare coating
Resolution Capabilities	VGA to SXGA
Pixel Pitch	0.28mm
Active Display Area	14.135" x 11.308" 359.03mm x 287.27mm
Pixel Format	640 x 480, 800 x 600, 1024 x 768, 1280 x 1024
Viewing Angle (Left/Right)	80/80°
Viewing Angle (Up/Down)	80/80°
Contrast Ratio	350:1
Brightness	VT181P, VT181PSS, VT181R, VT181RSS, VT181W, VT181PI: 300 Nits Transflectives: over 1000 Nits*
Response Time	T _R = 15ms typical T _F = 15ms typical
Back Lights	Cold Cathode 50,000 Hrs. Half Life
Video Connector	HD15(F) DVI-I 29Pin connector (Digital/Analog) Composite Video (CVSC) S-Video (S-VHS)
Colors Supported	16.7M
Video Input	RGB Analog (0.7V p-p / 75ohm) , Digital CVBS (1.0V p-p) S-VHS, luma/chroma (.7V p-p / 75ohm)
Sync	Separate H&V, Combined, SOG (Sync On Green), Digital
Input Voltage	AC 100-240V 50/60Hz 1.0A
Power consumption	Normal: 55Watts DPMS: < 3Watts
Operating Temperature	0 to 50°C
Storage Temperature	-20 to 60°C
Operating Humidity	10 to 95%NC
Storage Humidity	10 to 95%NC
Operating Altitude	Up to 10,000 ft
Storage Altitude	Up to 40,000 ft

*Outdoor Brightness Equivalent (Varies depending upon sunlight brightness)

VARTECH SYSTEMS

HEADQUARTERS

11529 Sun Belt Ct.

Baton Rouge, Louisiana 70809

Toll-Free: 800.223.8050

International Phone: 001.225.298.0300

Fax: 225.297.2440

E-mail: sales@vartechsystems.com

www.vartechsystems.com