



Solutions for Demanding Applications

VarTech Systems Inc.

Industrial CRT and Flat Panel Displays



VT14A-C1

Console Mount
Auto Sync Color Monitor

User's Guide

Read these instructions completely before attempting to operate your new Color Display.

TABLE OF CONTENTS

Sections		Page
1	Warning and Caution	1
2	Video Connections	2-3
	5BNC Connectors	4
3	Controls	5
	Mode Operations	6
4	Chassis Mount Mechanical	7
5	Specifications	8

1

SAFETY WARNINGS

The following warnings and cautions are for your safety, for the prevention of injury from electric shock and for the safe operation of the monitor. Please read them carefully.

- ◆ Do not block the ventilation slots or insert any objects into the monitor through them.
- ◆ Do not spill water onto the monitor or spray aerosol cleaners directly onto its surfaces when cleaning.
- ◆ Always position and operate the monitor on a stable and safe surface.
- ◆ Do not install the monitor in a damp area, or where it may be exposed to rain or other sources of water.
- ◆ Ensure that all accessible cables cannot be walked on, tripped over or damaged by furniture or other transportable objects.
- ◆ If the monitor is damaged or fails to function correctly, disconnect it from the AC source. Do not attempt to repair it yourself. Consult a qualified service technician.
- ◆ Serious electrical shock hazards exist within the covers of the monitor. Under no circumstances should these covers be removed.

WARNING

Changes or modifications to this unit not expressly approved by the party responsible for compliance could void the user's authority to operate the equipment.

NOTE

This equipment has been tested and found to comply with the limits for a class B digital device, pursuant to part 15 of the FCC rules. These limits are designed to provide reasonable protection against harmful interference in a residential installation. This equipment generates, uses and can radiate radio frequency energy and, if not installed and used in accordance with the instructions, may cause harmful interference to radio communications. However, there is no guarantee that interference will not occur in a particular installation. If this equipment does cause harmful interference to radio or television reception, which can be determined by turning the equipment off and on, the user is encouraged to try to correct the interference using one or more of the following measures:

- Reorient or relocate the receiving antenna;
- Increase the separation between the equipment and the receiver;
- Connect the equipment into an outlet on a circuit different from that to which the receiver is needed;
- Consult the dealer or an experienced radio/TV technician for help.

2

VIDEO CONNECTIONS

Video Signal Correction

The monitor is supplied with a 15pin HD connector (HD15F) and 5BNC input connectors arranged as shown below:

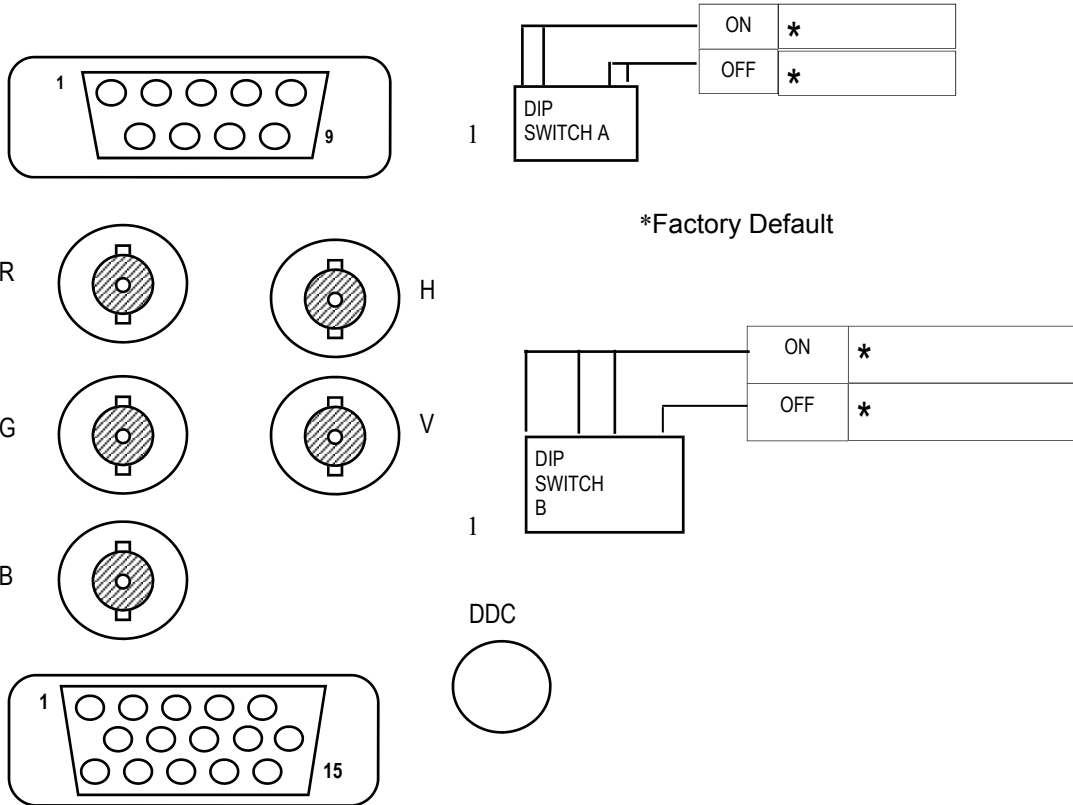

15 Pin D CONNECTOR: This is an industry standard connector providing easy connection to VGA type video sources.

PIN	FUNCTION	PIN	FUNCTION
1	Red Video In	8	Blue Return
2	Green Video In	9	NC (grounded in monitor)
3	Blue Video In	10	Digital ground
4	NC	11	Digital ground
5	NC	12	NC
6	Red Return	13	Horizontal sync
7	Green Return	14	Vertical sync
		15	NC

VIDEO CONNECTIONS CONT.

9 Pin D CONNECTOR: This connector allows the monitor to work with TTL video signals. It is compatible with industry standard EGA and CGA signals. In addition it can be configured for 3, 4 or 6 bit TTL video from other types of video source.

Pin Number	Function		
		3 bit video	4 bit video
			6 bit video
1	GND (ov)	GND (ov)	GND (ov)
2	NC	NC	Red Intensity
3	Red	Red	Red
4	Green	Green	Green
5	Blue	Blue	Blue
6	NC	Intensity	Green Intensity
7	NC	NC	Blue Intensity
8	Horiz sync	Horiz sync	Horiz sync
9	Vert sync	Vert sync	Vert sync

DIP SWITCH (A) SETTINGS: SW1 and SW2 control the number of TTL colors.

SW1	SW2	Colors
OFF	OFF	8
OFF	ON	16
ON	OFF	64
ON	ON	AUTO 16/64

Video Levels: 0.7v p-p into 75Ω

Syncs: Separate H and V syncs TTL levels

In the majority of cases the monitor will connect directly to a PC type computer using the cable supplied.

5BNC CONNECTORS

These connectors allow the monitor to work with Red, Green and Blue coaxial cable. The monitor synchronization may be Sync on Green, Composite sync or Separate Horizontal and Vertical sync. The "H" input is used for composite sync.

Video inputs:

Red, Green, Blue. 0.7v p-p into 75 Ω

Sync inputs:

1. Sync on green 0.3v p-p into 75 Ω superimposed onto green video. (3 wire)
2. Composite sync TTL level, positive or negative, combined horizontal or vertical sync. (4 wire)
3. Separate syncs TTL level, positive or negative, separate horizontal and vertical sync. (5 wire)

DIP SWITCH (B) SETTINGS

SW1,2,3 75 Ω / Hi Z. The input impedance of the Red, Green, Blue BNC inputs can be switched between 75 Ω and High impedance. For normal operation the switches should be in the ON position (75 Ω). If it is required to connect more than one monitor to a single video source (loop through) then the switches may be switched to OFF so that the combined input impedance of more than one monitor remains at 75 Ω . These three switches have no effect on the 15 way D input connector.

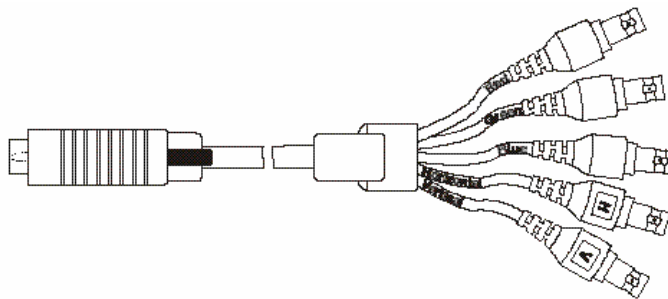

3

DIGITAL CONTROLS

DIGITAL CONTROLS

The digital controls are located on the rear side of the monitor.

Normal Mode Controls

Operates the functions when the LED power is on continuously.

Function Mode Controls

Operates the functions when the LED is flashing.



Function Key

Press to switch between *normal mode* (LED will stop flashing) and *function mode* (LED will start flashing).

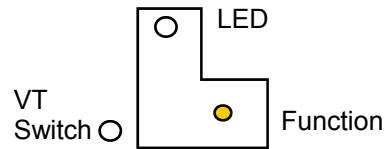

Contrast

Press “-” to decrease
Press “+” to increase

Program Store*

Press to save picture alignment.
(Also returns monitor to *normal mode*)

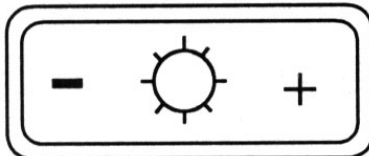

Brightness

Press “-” to decrease
Press “+” to increase

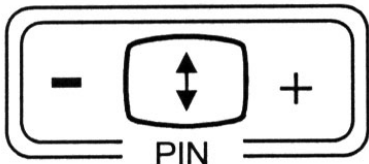

Vertical Size

Press “-” to decrease size
Press “+” to increase size

Pincushion*

Press to adjust curvature of picture sides

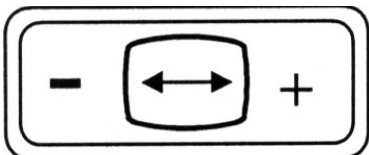

Horizontal Size

Press “-” to decrease size
Press “+” to increase size



Vertical Position

Press “-” to move picture down
Press “+” to move picture up

Keystone*

Press “-” or “+” to make sides of picture parallel

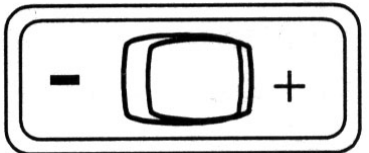

Horizontal Position

Press “-” to move picture left
Press “+” to move picture right

* Press Function button. LED will blink allowing for keystone, store program and pincushion adjustments.

MODE OPERATIONS

In the normal mode of operation, the LED is not flashing.

Disable Keypad

1. Press and release the **FUNCTION** (upper right) switch. The LED will now be flashing.
2. Simultaneously press the **FUNCTION** and the **VT** (upper left) switches. Note that the **VT** switch is not labeled. The LED will momentarily be off and then resume flashing.
3. Press and release the **FUNCTION** (upper right) switch. The LED will not be flashing.
4. To enable the keypad, repeat the above steps.

Factory Default Settings

1. Press and release the **FUNCTION** (upper right) switch. The LED will now be flashing.
2. Simultaneously press the **VT** switch and the **VERTICAL SIZE +** (bottom right) switches. The LED will momentarily be off and then resume flashing. All stored setups will be deleted except original factory setups.
3. Press and release the **FUNCTION** (upper right) switch. The LED will not be flashing.

Display Storage

1. Adjust the display for Brightness, Contrast, Horizontal Position, Horizontal Size, Vertical Position, Vertical Size. This is done while the LED is not flashing.
2. Press and release the **FUNCTION** (upper right) switch. The LED will now be flashing.
3. Adjust the display for Keystone and Pincushion.
4. Press the **CONTRAST +** switch. This will store the display and return the keypad to normal operation. The LED will not be flashing.

Horizontal frequency bands			
Band	Frequency Range	Band	Frequency Range
1	<14.96kHz	9	33.42 - 36.28kHz
2	14.96 - 16.87kHz	10	36.82kHz—40.74kHz
3	16.87 - 19.10kHz	11	40.74 - 46.79kHz
4	19.10 - 22.60kHz	12	46.79 - 49.02kHz
5	22.60 - 24.83kHz	13	49.02 - 52.52kHz
6	24.83 - 27.69kHz	14	52.52 - 57.29kHz
7	27.69 - 29.28kHz	15	57.29 - 60.16kHz
8	29.28 - 33.42kHz	16	>60.16kHz

Vertical frequency bands	
Band	Frequency Range
1	<56Hz
2	56 - 65Hz
3	65 - 78Hz
4	>78hz

ENGINEERING SPECIFICATIONS	
Size	14"
Pitch	.28mm
Deflection Angle	90°
Phosphor	Medium Short B22
Resolution Capabilities	CGA to SVGA
Active Display Area	11.25" x 8.25" / 285.75mm x 209.55mm
Power Source	90 - 265 volts AC autoranging 50/60 Hz, 1.5 amps ac
Power Consumption	90 Watts
Horizontal Frequency	15kHz to 40kHz
Vertical Frequency	40Hz to 100Hz
Bandwidth	65MHz
Video Input Connector	HD15(F) and 5BNC, Optional DB9
Video Input Signal	Analog 0.7 p-p / 75Ω or TTL 3, 4 or 6 bits
Sync	Separate or Composite Sync:TTL pos. or neg. Sync:TTL pos. or neg. Sync on Green (SOG) 0.3V p-p, negative
Temperature	Operating: 0 to 50°C Storage: -20 to 60°C
Humidity	Operating: 20 to 80% NC Storage: 10 to 90% NC
Degaussing	Automatic at power ON & Manual
Note: For continued compliance with Electromagnetic Compatibility limits, this monitor must be used with the signal lead supplied.	

VARTECH SYSTEMS INC.

HEADQUARTERS

11529 Sun Belt Ct.

Baton Rouge, Louisiana 70809

Toll-Free: 800.223.8050

International Phone: 001.225.298.0300

Fax: 225.297.2440

E-mail: sales@vartechsystems.com

www.vartechsystems.com