



Solutions for Demanding Applications

VarTech Systems Inc.

Industrial CRT and Flat Panel Displays



VT190 ColorVue Series

19.0" Flat Panel Series LCD Monitors

VT190PC

VT190RC

User's Guide

Read these instructions completely before attempting to operate your new Color Display.

Table Of Contents

Section	Page	Section	Page
Section 1		Section 5	
Introduction		Touch screen	14
1.1 About LCD Monitors	1	5.1 Introduction	14
1.2 Product Safety Precautions	2	5.2 Installation	14
Section 2		Section 6	
Display Setup		Troubleshooting Tips	15
2.1 Display Features	3		
2.2 Unpacking The Display	4	Section 7	
2.3 Included Parts	4	Cleaning & Maintenance	16
2.4 Connecting Your Display	4		
2.5 Signal Connections	4-6	Section 8	
		Mechanical Drawings	17
Section 3		Panel Mount Mechanical Drawings	18-19
Getting Started		Rack Mount Mechanical Drawings	20
3.1 Adjusting the Display	7		
3.2 Control Panel Functions	7	Section 9	
3.3 OSD Adjustment	8-12	Display Specifications	21
Section 4			
Display Timing	13		

1

1.1 About LCD Monitors

What you gain by using an LCD monitor in your industrial controls

LCDs are the future of display technology. Although CRTS have dropped in cost significantly, they do not offer the performance, reliability, and mounting options available with LCDs. LCD monitors consist primarily of an LCD, Video Board and a Back Light video. The LCD determines to a large extent the viewing angle, brightness and contrast. Beyond that it is the function of the video board which converts the analog RGB (Red, Green, Blue) signals from a standard video card to a high quality, digital RGB that the LCD can display.

Recently the video card has taken on a new role. It is the responsibility of this device to “scale” a particular video resolution to the “native” resolution of the LCD. Simply, consider that a computer is putting out a VGA [640x480] resolution signal, yet the LCD that is connected is an XGA [1024x768] display. The displayed picture would be in the center 1/3 of the LCD. With the introduction of the scaling engine. The converter will mathematically recalculate the 640x480 to 1024x768. This may sound simple but it is in fact a complex algorithm that adjusts for different aspect ratios and pixel alignment, essentially smoothing text and graphics to produce a picture that is pleasant to the eye.

All Vartech displays from 12.1” (800x600) to 23.1 (1600x1200) incorporate scaling engines in the converter card.

1.1 Product Safety Precautions

- ⇒ Ensure that sufficient space is available around the display to provide the circulation necessary for cooling.
- ⇒ Ensure that the ambient air temperature will not exceed the specified maximum temperature.
- ⇒ Do not attempt to service this display yourself. The rear chassis has a seal so that non qualified personal will not expose themselves to dangerous voltages or other risks.
- ⇒ To protect from electrical shock, unplug the display power supply from the wall before moving.
- ⇒ Do not expose the display to direct sunlight or heat.
- ⇒ Do not use this display near water
- ⇒ Do not place any heavy objects on the power cords. Damage may cause electrical shock.
- ⇒ Unplug the power supply from the wall or unit if one of the following conditions exists.
 - ⇒ Power cord or plug is damaged or frayed
 - ⇒ Liquid is spilled into the display or the display is exposed to rain or water.
 - ⇒ The display does not operate normally when the operating instructions are followed.
 - ⇒ The display has been dropped or the enclosure has been damaged.
 - ⇒ The display exhibits a distinct change in performance, indicating a need for service.

2

2.1 VT190 ColorVue Series Display Features

- ⇒ Capable of displaying unlimited colors in a continuous spectrum. The high contrast LCD enhances the image with no geometric distortion.
- ⇒ The VT190 ColorVue Series directly accepts an analog 5 wire RGB with separate H/V sync.
- ⇒ The VT190 ColorVue Series is auto synchronous adjusting the display to the appropriate input between VGA, SVGA, XGA, and SXGA.
- ⇒ The VT190 ColorVue Series is available in Panel Mount, Rack Mount, or Wall Mount industrial packages.
- ⇒ The VT190 ColorVue Series is supplied with a Anti-Reflective Screen unless equipped with an optional Touch System.
- ⇒ The VT190 ColorVue Series has an integrated 115/220VAC supply as standard on all models.

2.2 Unpacking and setting up your display

Your LCD monitor package will consist of the components listed below. Open shipping container and lay all components on a flat clean surface.

2.3 What is included with your display

- ⇒ VT190RC or VT190PC LCD Monitor
- ⇒ 5 ft Video Cable
- ⇒ 10-32 Mounting Hardware. (For use with Panel Mount only)
- ⇒ 6 ft RS232 Touch Interface Cable (Optional when touch is installed)
- ⇒ CD ROM with Touch Screen Drivers (Optional when touch is installed)
- ⇒ Users Guide (Printed or on CD)

2.4 Connecting the Display

1. Connect all cables to the computer first. This would include the VGA cable and the optional RS 232 serial touch screen connection.
2. After connecting the cables between the LCD monitor and the computer, plug the power cord into the 115/220VAC power outlet.
3. Once the 115/220VAC connection is made, the display is active.
4. If your computer was off, turn on your computer.
5. Your display should now operate as a normal computer display showing your windows or whatever video is being sent to the flat panel.

Note: If for any reason the display goes blank and gives an “out of Range” or “No Input Signal”, your computer or video source is putting out a signal that is out of range of the LCD’s video board. If this happens, reboot the computer or video source and make sure you are inputting the correct signal. If the display doesn’t work properly, it may be because:

- (a) The resolution is too high or low for the LCD.
- (b) The refresh rate is set too high. Refresh on an LCD is different than a CRT. Set the refresh to 60Hz. CRT’s need a high refresh rate to avoid flicker. The refresh rate has no impact on LCD’s.
- (c) The power source is incorrect.
- (d) The unit is malfunctioning. If you believe this to be true, disconnect the video cable from the rear of the LCD and connect to a known good computer CRT display. If the computer display is working satisfactory and the video is within the appropriate range, then contact Vartech Customer service for a RMA number at 800-223-8050.

2.5 Signal Connections

To avoid irregular operation and /or damage to the display, please insure correct video is being supplied as shown on the following page.

2.5 Signal Connections Cont.

You can use an HD-15 connector cable or a BNC adapter cable to connect the flat panel monitor to the host computer. The HD-15 video cable (supplied in the kit) you use with this monitor is equipped with a conventional HD-15 connector at each end.

Note: The following figure is the view looking into the pin end of the male connector or solder term end of the female connector.

HD-15 Video Connector

The following table provides the pin numbers and corresponding pin assignments for the HD-15 video connector.

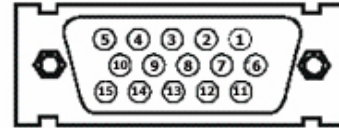

Pin	Signal (HD15)	Pin	Signal (HD15)	Pin	Signal (HD15)
1	Red Video	6	Red Video Ground	11	Monitor Ground
2	Green Video	7	Green Video Ground	12	DDC data
3	Blue Video	8	Blue Video Ground	13	Horizontal Sync
4	Not Used	9	+5 V	14	Vertical Sync
5	Ground	10	PC detection	15	DDC clock

DVI-I Connector (Digital / Analog)

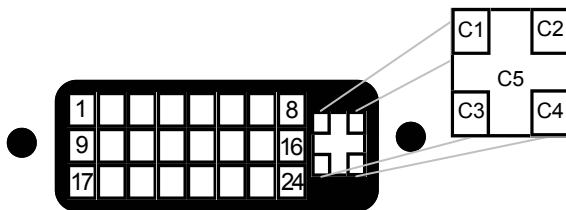

Pin	Signal (DVI-I)
C1	Not Used
C2	Not Used
C3	Not Used
C4	Not Used
C5	Not Used

Pin	Signal (DVI-I)	Pin	Signal (DVI-I)	Pin	Signal (DVI-I)
1	T.M.D.S. Data2-	9	T.M.D.S. Data1-	17	T.M.D.S. Data0-
2	T.M.D.S. Data2+	10	T.M.D.S. Data1+	18	T.M.D.S. Data0+
3	SGND	11	SGND	19	SGND
4	Not used	12	Not used	20	Not used
5	Not used	13	Not used	21	Not used
6	DDC Clock	14	DDC Power	22	SGND
7	DDC Data	15	Ground	23	T.M.D.S. Clock+
8	Not used	16	Hot Plug Detect	24	T.M.D.S. Clock-

2.5 Signal Connections Cont.

Optional BNC Adaptor Cable

An HD-15 to 5-BNC adapter cable is available. The functions of the cables are described below.

- ⇒ **R, B, and G:** Red, Green, and Blue input connectors to establish color. These are used for RS-343 analog signals.
- ⇒ **HS:** Separate horizontal sync signal from the video source.
- ⇒ **VS:** Separate vertical sync signal from the video source.

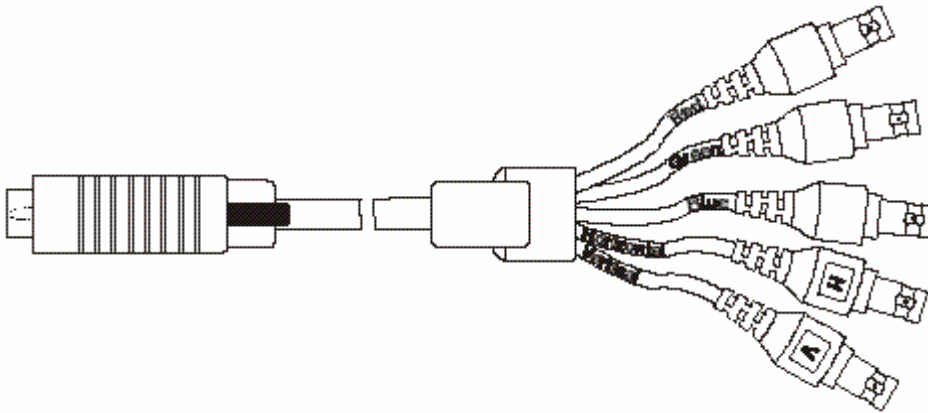

3

Getting Started

3.1 Adjusting the display

The VT190 Series display has an embedded microprocessor in the converter card. Once you have the unit displaying the resolution you desire for your application do the following:

In order to navigate to the appropriate adjustments, press **Menu** and the OSD layout chart will appear as indicated in Fig. 1 from left to right.

If you press the “MENU” the new settings are saved and the OSM appear and your setting will be stored in the unit’s non volatile memory.

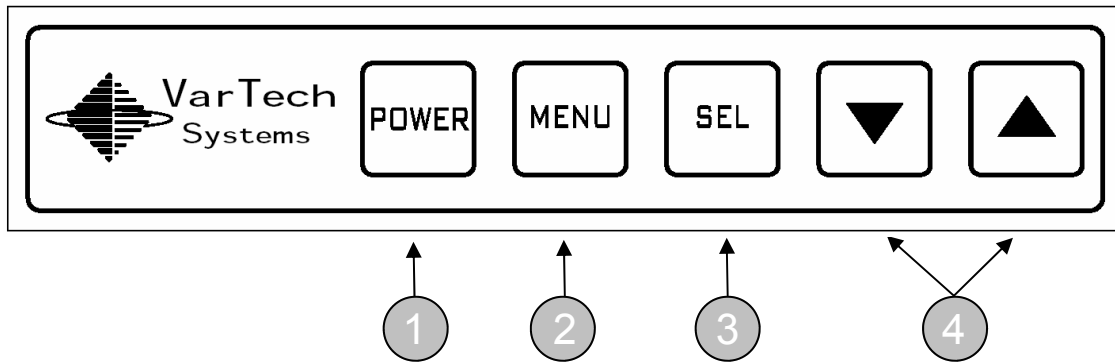

3.2 Control Panel Functions

Control	Function
① POWER	Use this button to turn the monitor on and off.
② MENU	Use this button to enter or exit the On Screen Display.
③ SEL	Use this button to enter a selection in the On Screen Display.
④ ▼ ▲	Use these button to choose or adjust items in the On Screen Display.

3.3 On Screen Display (OSD) Control Adjustment

Screen Adjustment Operation Procedure

1) Entering the Screen Adjustment

The setting switches are normally at stand-by. Push the MENU button once to display the main menu of the screen adjustment. The adjustable items will be displayed in the main menu.

2) Entering the Settings

Use the Adjust ▼ and Adjust ▲ buttons to select the desired setting icon and push the SELECT button to enter sub-menu.

3) Change the Settings

After the sub-menu appears, use the Adjust ▼ and Adjust ▲ buttons to change the setting values.

4) Save

After completing the adjustment, push the SELECT button to save the setting.

5) Return & Exit the Main Menu

Exit the screen adjustment, push the 'SELECT' button and the 'EXIT' of "MISC MENU". When no operation is done around 60 sec (default OSD timeout), it goes back to the stand-by mode and no more switching is accepted except MENU to restart the setting.

3.3 On Screen Display (OSD) Control Adjustment Cont.

The following table indicates all the On Screen Display control, adjustment, and setting menus.

Main Menu	Sub Menu		A	D	Reference
BRIGHTNESS	BRIGHTNESS		✓	✓	To adjust the brightness and contrast of the screen
CONTRAST	CONTRAST		✓	✓	
COLOR	PRESET	9300K	✓		To customize the color of the screen
		6500K	✓		
	R/G/B (User Color)		✓		
POSITION	V POSITION		✓		To adjust the position of the screen
	H POSITION		✓		
TRACKING	CLOCK		✓		To improve the clarity and stability of the screen
	PHASE		✓		
SETUP	AUTO CONFIG		✓		To customize the screen status for a user's operating environment
	INPUT		✓	✓	
	INFORMATION		✓	✓	
	RECALL		✓	✓	
	AUDIO				
	OSD ADJUST		✓	✓	
EXIT	EXIT		✓	✓	To Exit the OSD

Legend

✓: Adjustable

A: Analog Input
D-SUB

D: Digital Input
DVI-D





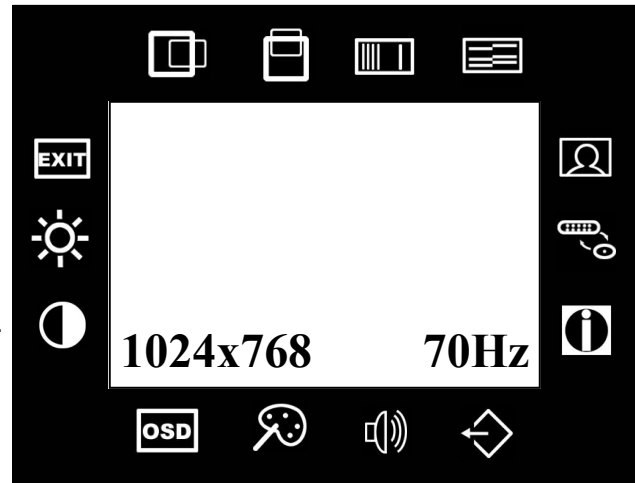

3.3 On Screen Display (OSD) Control Adjustment Cont.

The OSD main menu is displayed on screen when MENU key is pressed. The OSD menu is a combination of graphic and text display. The first line always shows the current selected or active menu item. The bottom line of main menu shows information of the input image.

The UP and DOWN keys are used to scroll through items within the menu. The selected item is highlighted as the scrolling move along. The SELECT key is used to activate the highlighted item. During this state, the MENU key is used to close the OSD menu from the screen.







OSD - On Screen Display

Icon	Function	Description
	BRIGHTNESS	Adjusts the brightness of the screen.
	CONTRAST	Adjusts the contrast of the screen.
	PRESET	COLOR 9300K / 6500K <ul style="list-style-type: none"> • 9300K: Default to 9300K color temp • 6500K: Default to 6500K color temp • User Mode: Used to adjust RGB
	RED (user mode)	Adjusts the gain of red channel in ADC.
	GREEN (user mode)	Adjusts the gain of green channel in ADC.
	BLUE (user mode)	Adjusts the gain of blue channel in ADC.
	VERTICAL POSITION	Moves the image up and down.
	HORIZONTAL POSITION	Moves the image left and right.
	INPUT	Selects the applicable input source, analog input (D-SUB), or Digital input (DVI-D)
	INFORMATION	Provides the user with detailed information regarding the current input format and version.

3.3 On Screen Display (OSD) Control Adjustment Cont.

OSD - On Screen Display

Icon	Function	Description
	CLOCK	Adjusts the number pixels per line
	PHASE	Adjusts the ADC pixel clock
 	AUTO CONFIG D-SUB Input source only	Use the ▲ and ▼ buttons to scroll up and down in the menu, then press the SELECT key to start this function. If the MENU key is pressed, the main menu is re-displayed and nothing is changed.
	Auto Adjust	Performs automatic configuration of the phase, clock, vertical position and horizontal position.
	Auto Tracking	Tunes the clock and phase to the best condition automatically.
	Auto Position	Centers the image automatically. Both horizontal and vertical position are adjusted so that the image is centered on the display.
	Auto Color	Adjusts the gain and offset of the RED, GREEN and BLUE channels on the ADC automatically.
	Return	Goes back to main menu.

How to use the AUTO CONFIG Adjustment

This function tunes the parameters of PHASE, CLOCK, H-POSITION, and V-POSITION.

Suggested steps for Auto Config Adjustment:



- 1) Enter the “Windows” Shut-down frame.

Note:

The Wallpaper color **CAN NOT** be black.

- 2) Enter OSD Main menu and choose the AUTO CONFIG item, then press the SELECT key. The picture will auto-adjust by itself. After 4 seconds, you can exit OSD and Shut-down frame.
- 3) If you are not still satisfied with the picture quality, you could choose CONTRAST item in OSD Main Menu and adjust it.

3.3 On Screen Display (OSD) Control Adjustment Cont.

OSD - On Screen Display		
Icon	Function	Description
	OSD ADJUST	Adjusts miscellaneous OSD settings
	OSD Position	Used to setup the OSD menu position. The item "OSD POSITION" is used to setup the OSD menu position. The OSD menu horizontal and vertical position is adjusted separately. Each position adjustment item will bring up the slider window. The maximum value of the sliders are based on the size do the OSD menu.
	Black Level Adjust	Used to adjust the black level (zero level offset) of the AD converters.
	Language	Used to select the OSD menu in 5 languages: English, German, French, Italian, Spanish
	Sharpness	This can adjust the video quality to be sharp or blur.
	AUDIO ADJUST	Currently Not Available
	Volume	Increases and decreases the volume. Mutes the audio.
	Balance	Adjusts the proportion of sound coming from each speaker.
	Bass	Adjusts the low (bass) frequency audio output.
	Treble	Adjusts the high (treble) frequency audio output.
	Mute	Temporarily silences audio output.
	RECALL	Reloads all factory default parameters.

Note:

If you don't press any keys during 45 seconds, the OSD will disappear by itself and not save the parameters.

4

Display Timing

Applicable Video Timing

The following table lists the better display quality modes that these LCD monitors provide. If the other video modes are input, the monitor will stop working or display unsatisfactory picture quality.

VESA MODES					
			Horizontal	Vertical	VCLK
Mode	Resolution	Total	Nominal Frequency +/- 0.5KHz	Nominal Frequency +/- 1KHz	Nominal Pixel Clock (MHz)
DOS	720 x 400 @ 70Hz	900 x 449	31.469	70.087	28.322
VGA	640 x 480 @ 60Hz	800 x 525	31.469	59.940	25.175
	640 x 480 @ 72Hz	832 x 520	37.861	72.809	31.500
	640 x 480 @ 75Hz	840 x 500	37.500	75.000	31.500
SVGA	800 X 600 @ 56Hz	1024 x 625	35.156	56.250	36.000
	800 X 600 @ 60Hz	1056 x 628	37.879	60.017	40.000
	800 X 600 @ 72Hz	1040 x 666	48.077	72.188	50.000
	800 X 600 @ 75Hz	1056 x 625	46.875	75.000	49.500
XGA	1024 x 768 @ 60Hz	1344 x 804	48.363	60.004	65.000
	1024 x 768 @ 70Hz	1328 x 806	56.476	70.069	75.000
	1024 x 768 @ 75Hz	1312 x 800	60.023	75.029	78.750
	1152 x 864 @ 75Hz	1600 x 900	67.500	75.000	108.00
SXGA	1280 x 1024 @ 60Hz	1688 x 1066	63.981	60.020	180.00
IBM MODES					
EGA	640 x 350 @ 70Hz	800 x 449	31.469	70.086	25.175
DOS	720 x 400 @ 70Hz	900 x 449	31.469	70.087	28.322
VGA	640 x 480 @ 60Hz	800 x 525	31.469	59.940	25.175
XGA	1024 x 768 @ 72Hz		57.515	72.100	75.000
MAC MODES					
VGA	640 x 480 @ 60hz	800 x 525	31.469	59.940	25.175
SVGA	832 x 624 @ 75Hz	1152 x 667	49.725	74.551	57.283
XGA	1024 x 768 @ 75Hz	1328 x 804	60.241	74.927	80.000

5

Touch Screen

5.1 Introduction

Touch screens are a common means to interface operator inputs to a system. The universal standard of Windows GUI (Graphical User Interface) has significantly increased the use of touch screens.

There are four main touch technologies. The technologies are resistive, surface acoustic wave (SAW), capacitive, and infrared (IR). Each touch technology has advantages and disadvantages based on different user applications.

5.2 Installation

All Vartech Systems displays configured with a touch screen are supplied with a CDROM which includes user manuals, application software, and drivers for various operating systems. Insert the supplied CDROM into a CDROM drive and follow the installation instructions that will appear on the screen.

Limited technical support is available by contacting Vartech Systems customer support at 800-223-8050.

Problem	Troubleshooting Tip
No image on display screen	<ol style="list-style-type: none"> 1) Check that the power cord of the Computer has been connected securely into wall outlet or grounded extension cable or strip. 2) Check that the power switch of the Display has been pressed and the LED on the front of the Display is lit. 3) Check that the Video (Signal) Cable from the Display has been securely and correctly connected. 4) Check that the Video Card is firmly seated in card slot of Computer motherboard. 5) Check that the Video Input from the Video Card falls within the timing range of the Display. (see Display Timing - Section 4)
Abnormal image	<ol style="list-style-type: none"> 1) Check that the Video Input from the Video Card falls within the timing range of the Display. (see Display Timing - Section 4) 2) Check that the Video (Signal) Cable from the Display has been securely and correctly connected to the Video Connector at the rear side of the Computer.
Colors of image on screen are abnormal	<ol style="list-style-type: none"> 1) Check that the Video (Signal) Cable from the Display has been securely and correctly connected to the 15Pin Video Connector at the rear of the computer.
Disturbances on Screen	<ol style="list-style-type: none"> 1) OSD adjustment is incorrect. (See OSD screen adjustment procedures Section 3)

7

Cleaning and Maintenance

Cleaning

Occasionally clean the display panel and cabinet with a soft cloth dampened (not soaked) with a mild (non-abrasive) glass cleaner. Keep turning a fresh side of the cloth toward the screen surface to avoid scratching it with accumulated grit.

Note: The solvent (a 50/50 mixture isopropyl alcohol and water) should be applied only to the cloth, and not directly on the monitor screen.

Do not use paper products as they may scratch the surface. To minimize the risk of abrasion, allow the screen to stand dry.

Special care should be taken when cleaning a touch screen or polycarbonate shield that is installed over the screen. Abrasive and certain chemical cleaners can easily damage the surface.

Never use alcoholic or ammoniac cleaners to clean the polycarbonate shield or a touch screen.

Replacing a Line Cord

To avoid shock and fire hazards, the monitor's power cord should be replaced if the insulation becomes broken or if it develops a loose internal connection.

Other Maintenance

Qualified service personnel should perform all maintenance, except for the power cord replacement described above.

Mechanical Drawings

Model	Description	Page(s)
VT190PC	19.0" ColorVue Panel Mount Mechanical Drawing	18-19
VT190RC	19.0" ColorVue Rack Mount Mechanical Drawing	20

7.1 Panel Mount Procedure

Panel Mounting Procedure

1. Cut and drill the panel (refer to panel mount drawing). Measurements are in inches.

Panel Mounting Cutout

2. If access to the side of the monitor is not available following installation, attach the power and video cables to the side of the monitor at this time.
3. Install the monitor in the prepared cutout.
4. Install the lock nuts and washers, supplied with the monitor, behind the holes running along the sides and top/bottom of the cutout in the panel. Extra lock nuts and washers are provided.

Note:

Use #10-32 nuts for mounting.

5. Tighten all mounting nuts evenly to a torque of 24 inch-pounds.

ATTENTION: Mounting nuts must be tightened to a torque of 24 inch-pounds to provide panel seal and avoid potential damage. Vartech Systems assumes no responsibility for water or chemical damage to the monitor or other equipment within the enclosure due to improper installation.

6. Attach the power and video cables to the side of the monitor if you have not already done so.

Generic Panel Mount Diagram

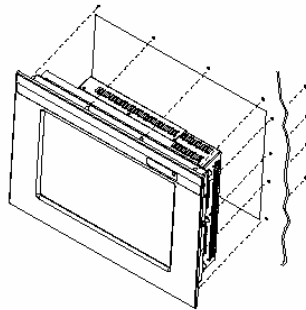

9

Specifications

Panel Size	19.0"
Type	TFT Active matrix w/ Anti-Glare coating
Pixel Pitch	0.297mm
Resolution	SXGA 1280 x 1024 max
Active Diagonal	19.0" Viewable
Active Screen Area	14.8" x 11.85" 376mm x 301mm
Pixel Format	640 x 480, 800 x 600, 1024 x 768, 1280 x 1024
Viewing Angle (Up/Down)	85/85 deg.
Viewing Angle (Left/Right)	85/85 deg.
Contrast Ratio	500:1
Brightness	250 Nits
Response Time	T _R = 15ms T _D = 10ms
Back Lights	Cold Cathode 50,000 Hrs. Half Life
Video Connectors	HD15(F) DVI-I 29Pin connector (Digital/Analog)
Video Input	RGB Analog (0.7V p-p / 75ohm), Digital
Sync	TTL level, Positive/Negative, Separate H&V
Horizontal Sync	30-82kHz
Vertical Sync	56-75Hz
Colors Supported	16.7M
Power Input	AC 100-240V 50/60Hz 1.0A
Power consumption	70 Watts @ 115VAC
Operating Temperature	0 to 50°C
Storage Temperature	-20 to 60°C
Operating Humidity	10 to 95% NC
Storage Humidity	5 to 95% NC
Operating Altitude	Up to 10,000 ft
Storage Altitude	Up to 50,000 ft

VARTECH SYSTEMS INC.

HEADQUARTERS

11529 Sun Belt Ct.

Baton Rouge, Louisiana 70809

Toll-Free: 800.223.8050

International Phone: 001.225.298.0300

Fax: 225.297.2440

E-mail: sales@vartechsystems.com

www.vartechsystems.com

150-077-001
8.27.04