

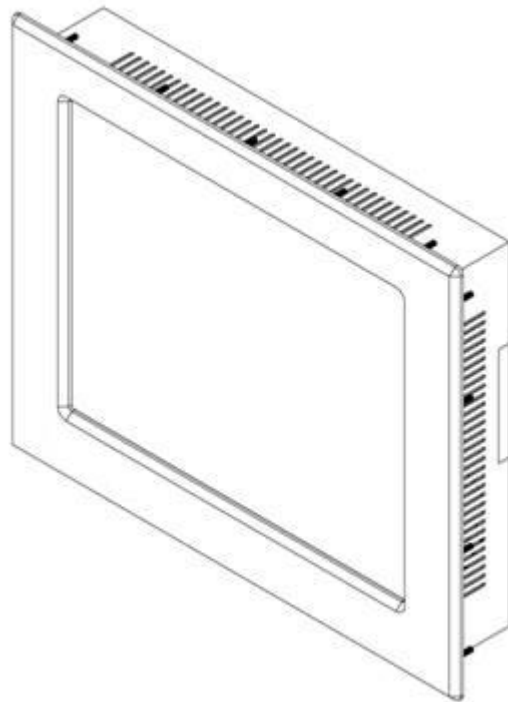

*Solutions for Demanding Applications*

**VARTECH**  
SYSTEMS INC.



## **19.0" Panel Mount PC**

**Model VTPC190P-F / PSS-F (Fanless)**

## **User's Guide**

Read these instructions completely before attempting to operate your new Panel Mount PC

## Revision History

Date	Rev No	Summary	Page
8/4/08	00	First Issue	
10/07/08	01	Revised panel mount drawing	6

## Safety Instructions

- Read the Safety Instructions carefully and keep it for use later.
- The chassis metalwork of the module must be installed properly to the main earthing termination for Class 1 equipment.
- Care must be exercised in the application of the system to prevent overheating. Ensure that the ambient temperature around the system does not exceed 50°C and provide adequate means of ventilation to achieve this.
- When cleaning cut off the electrical supply at all times. Never use liquid or aerosol detergent, use a soft damp cloth instead.
- Never insert anything metallic into the chassis openings. This may create an electric shock hazard or hazard from rotating fan blades.
- To avoid electric shock, never touch the inside of the system. There are no user adjustable components inside, only a qualified technician should open the system's case.
- Openings in the system enclosure are to allow for ventilation. To prevent overheating, these openings should not be blocked or covered.
- If the system does not operate normally – in particular, if there are any unusual sounds or smells coming from it – disconnect it immediately.
- Do not put pressure on the LCD panel screen because it is very fragile.
- Always handle the system with care when moving it.
- Take care that the system is disposed of correctly at the end of its life. If in doubt refer to your local ordinances or regulations for proper disposal.
- A socket-outlet shall be installed near the equipment and shall be easily accessible.

## Cleaning the LCD monitor

To clean the LCD panel:

- Wipe the screen gently with a clean lens brush made of camel hair, or a soft, clean, lint free cloth. This is to remove dust and other particles without scratching the LCD panel.
- If it is still not clean, then wipe with a damp lint free cloth and blow on it to dry.

Do not clean the panel with a keton-type material (e.g. acetone), or ethyl toluene, ethyl acid, methyl or chloride. These may damage the LCD panel.

Do not apply pressure to the LCD panel.

## Standard Technical Specifications:

### LCD Monitor:

<b>Size / Type</b>	19.0" SXGA TFT LCD
<b>Native Resolution</b>	1280 x 1024
<b>Contrast Ratio</b>	800:1
<b>Viewing Angles</b>	Horizontal: 178° Vertical: 178°
<b>Pixel Pitch</b>	0.294mm
<b>Brightness (typical)</b>	250 cd/m <sup>2</sup>
<b>Response Time (typical)</b>	7ms
<b>Colors Supported</b>	16.7 million

### Computer System:

<b>Processor</b>	Intel® Atom™ N270, 1.6 GHz processor
<b>System Memory</b>	DDR2 533 DIMM 1 GB
<b>BIOS</b>	AMI BIOS with LPC 2/4/8Mbit flash memory capacity
<b>Hard Drive</b>	320 GB SATA
<b>Operating System</b>	Microsoft XP Professional (SP3)
<b>Expansion Slots</b>	PCI x 1
<b>Back Panel I/O Ports</b>	PS/2 Keyboard Connector x 1 PS/2 Mouse Connector x 1 AC Power Inlet x 1 (IEC320) COMM Port x 1 (RS232) USB 2.0 Port x 4 RJ45 LAN Port x 2 VGA Port x 1 Audio Jacks: Line Out x 1 / Line In x 1 / MIC In x 1
<b>Graphics</b>	Integrated Uni-Chrome Pro II 3D/2D AGP Graphics
<b>LAN</b>	VIA VT6107 10/100 Mbps Fast Ethernet Controller
<b>DVD Drive (E-IDE / ATAPI)</b>	DVD-R, DVD+R, DVD-RW, DVD+RW, DVD-R DL, DVD+R9 CD-R, CD-RW,
<b>Touch Screen</b>	Capacitive

<b>Touch Screen Interface</b>	Standard: Serial Optional: USB	
<b>Power Input</b>	100 - 240 VAC 1.5A 50/60 Hz 12 / 24 VDC (Optional) 6 to 32 VDC without DVD (Optional)	
<b>Power Consumption</b>	70W	
<b>Temperature</b>	Operational: -32°F to 122°F Storage: -4°F to 149°F	0°C to 50°C -20°C to 65°C
<b>Humidity</b>	Operational: 20 to 40°C, 90% RH NC Storage: 5 to 65°C, 28% RH NC	

### Installation of Your Panel PC

Packaged with each carton will be:

- 1 - VTPC190P-F / PSS-F
- 1 - AC Power Cable
- 1 - #10-32 Mounting Hardware
- 1 - Users Guide (Printed or on CD)

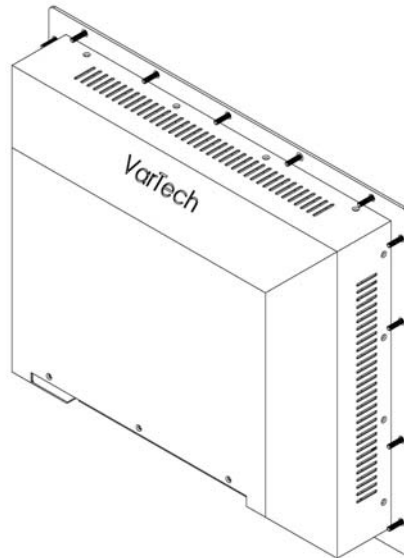

**BEFORE MAKING ANY CONNECTIONS OR APPLYING POWER,  
FIRST READ THROUGH THE ENTIRE MANUAL**

# Panel Mount Procedure

## Panel Mounting Procedure:

- 1- Cut and drill the panel (refer to the panel mount drawing, Figure A). Measurements are provided in inches and millimeters.

## Panel Mounting Cutout:

- 1- If access to the bottom of the enclosure is not available following installation, attach the power and all necessary cables to the bottom side of the enclosure at this time.
- 2- Install the enclosure in the prepared cutout.
- 3- Secure the enclosure using the lock nuts and washers, supplied with the unit, behind the holes running along the sides and the top and bottom of the cutout in the panel. Extra lock nuts and washers are provided.

**NOTE:** Use #10-32 nuts for mounting.

- 4- Tighten all mounting hardware to a torque of 24 inch-pounds.

**ATTENTION:** Mounting nuts must be tightened to a torque of 24 inch-pounds to provide a proper panel seal and avoid potential damage. Vartech Systems assumes no responsibility for water or chemical damage to the monitor or other equipment within the enclosure due to improper installation.

- 5- Attach the power, video and system cables to the bottom side of the enclosure if you have not already done so.

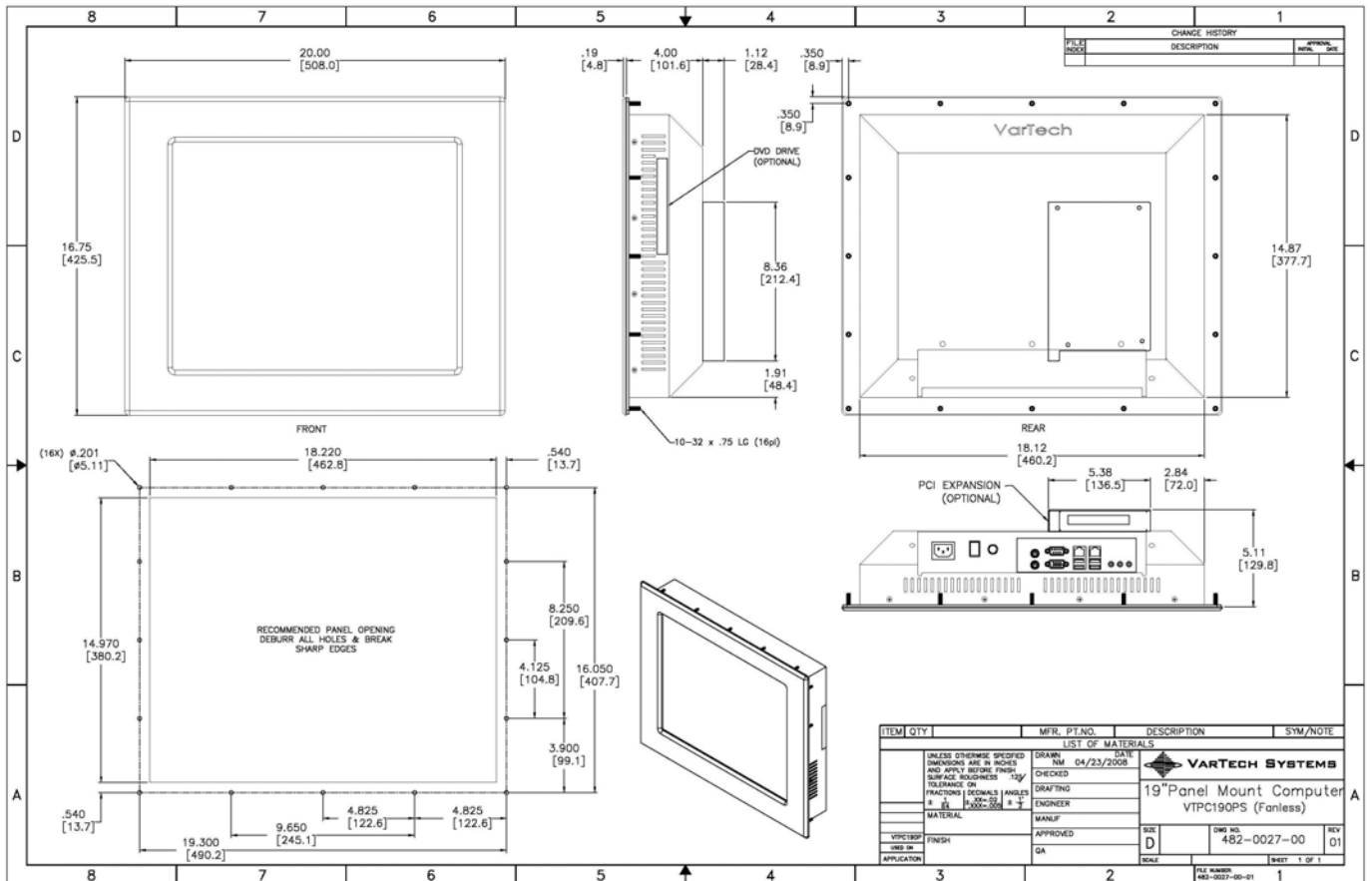

## Panel Mount Drawing: Detail –A–

### Connections to the Panel Mount PC

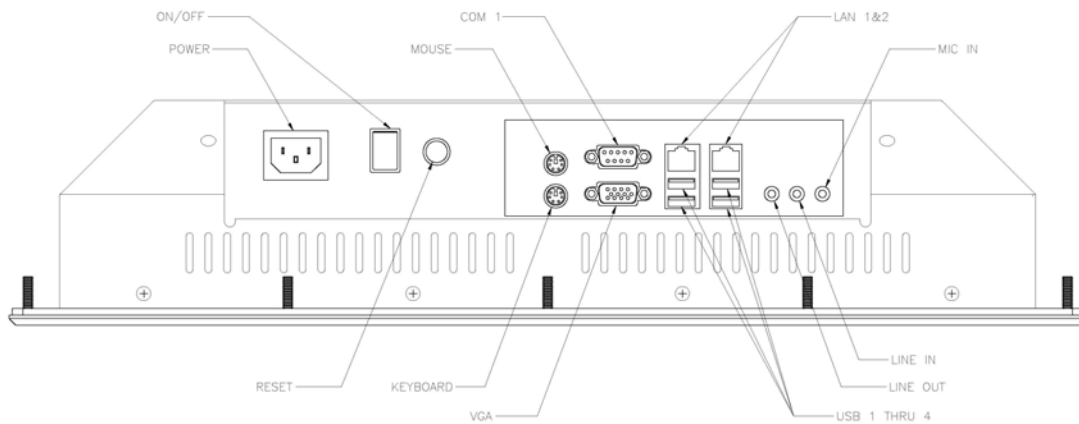

### Bottom Rear View - Connector Panel -

#### Power Connection (Power In)

The Panel Mount PC includes an AC line cord which is 6ft long. The power input receptacle is located on the bottom rear panel of the system.

#### Serial Connections (COM 1)

The Panel Mount PC is supplied with a serial connector configured for RS-232. The connector is a 9 pin female connectors and can be set up for any baud rate from 300 to 19.2 baud. The connector is located on the bottom panel of the system.

#### Ethernet Connections (LAN 1-2)

The Panel Mount PC is supplied with two integrated Ethernet connectors. The interface will support 10/100 BaseT connection to a local area network (LAN). The Panel Mount PC is supplied with two RJ-45 female connectors located on the bottom panel of the system.

#### USB Connections (USB 1-4)

The Panel Mount PC is supplied with four USB 2.0 connectors located on the bottom front panel of the system.

#### VGA Port

The 15-pin female VGA connector can be used to connect to any analog VGA monitor.

### **Turning the system On and Off**

Before connecting the Panel Mount PC to power, connect any peripheral devices. As a general rule, any peripheral device should only be connected or disconnected when the Panel Mount PC is off with the exception of any USB or 1394 peripheral.

The Panel Mount PC is turned on using the main On-Off rocket switch located on the bottom rear panel. Once the Panel Mount PC main switch is turned on the computer power pushbutton switch must be depressed for Windows to start. Windows must be properly shut down before the main power switch is turned off to prevent the chance of corrupting files in the operating system.

The Panel Mount PC is rated for continuous duty. However, to extend the life of the various components and conserve power, it is highly recommended that the system be properly shut down and power turned off when the Panel Mount PC is not in use.

### **LCD Monitor Warm-up Time**

All LCD monitors need time to become thermally stable the first time you turn them on. Therefore, to achieve more accurate adjustments for parameters, allow the LCD monitor to warm (be on) for at least 20 minutes before making any screen adjustments.

### **Maintenance**

The Panel Mount PC is designed to provide optimum service and performance with minimal maintenance including the occasional external cleaning. For cleaning the Panel Mount PC enclosure follow the suggested guidelines.

**General** – NEVER use abrasive cleaners or solvent-based cleaners!! Use a clean soft cloth. The Panel Mount PC should only be opened and serviced by a qualified technician. Keep the area around the Panel Mount PC clear and free of excessive dirt or other contaminants. Do not use water or any liquids on the Panel Mount PC.

For Additional Assistance  
Contact Your VarTech Sales Representative

Vartech Systems, Inc.  
11529 Sun Belt Ct.  
Baton Rouge, LA 70809

800-223-8050  
Fax: 225-297-2440

